

Inside Lifts

Installation & Owner's Manual



www.harmar.com | 800-833-0478



AL215

Single Axis Inside Lift
Capacity: 250 lbs.

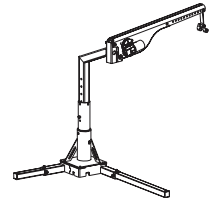

AL225

2-Axis Inside Lift
Capacity: 250 lbs.

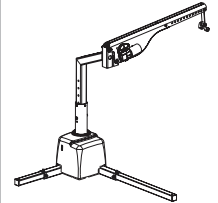

AL425

2-Axis Inside Lift
Capacity: 400 lbs.

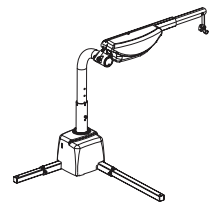

AL425HD

2-Axis Inside Lift
Capacity: 450 lbs.

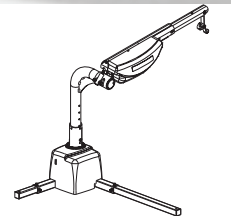

AL435

3-Axis Inside Lift
Capacity: 400 lbs.

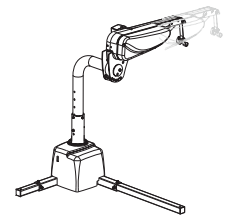

AL435T

Truck Lift
Capacity: 400 lbs.

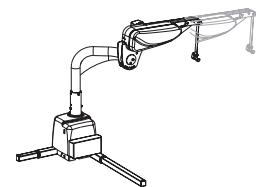

Read and understand this manual thoroughly before attempting to install or operate the lift. If you have any questions, please contact your Authorized Harmar Dealer or Harmar's Technical Service Department.

P 800-833-0478 | F 866-234-5680 | tech@harmar.com

TEC0091 2017DEC18 P/N: 999-3B01-AB Rev F

Dealer Name & Contact Information:

Serial # of Your Lift:

SECTION 1 : OWNER

OPERATING YOUR LIFT

Using Your Lift	2-4
Safety	5
Maintenance	6

SECTION 2: INSTALLER

PREPARATION

Understanding the Manual.....	7
Installation Overview	8
Tools Required.....	9
Unpacking the Lift	10

INSTALLATION

Wiring the Vehicle	11-12
Trial Fit Procedure.....	13
Base Installation: Flat Floor.....	14
Base Installation: 3rd Row Folding Seats	15-16
Base Installation: Truck Bed.....	17-20
Lift Installation	21-23

LIFT ADJUSTMENTS

Height.....	24
Pitch	25
Rotation	26-27
Docking Devices	28



TROUBLESHOOTING 29-30

EXPLODED VIEWS

AL215	31
AL225.....	32
AL425	33
AL425HD.....	34
AL435	35
AL435T.....	36
AL215 & AL225 Arm	37
AL425 Arm	38
AL425HD Arm	39
AL435 Series Arm.....	40
AL225 / AL425 / AL425HD / AL435 Series Base	41
AL425HD Base.....	42

ELECTRICAL DIAGRAMS

AL215	43
AL225 /AL425/AL425HD	44
AL435 AL435T	45

WARRANTY 46

NOTE: The following symbols indicate areas where you should take special care in order to avoid danger to individuals or property.



WARNING!

Hazardous situation to avoid possible serious injury to installer or user.



CAUTION!

Hazardous situation to avoid serious damage to property.

OPERATING YOUR LIFT

1. **Park power chair or scooter ready to be picked-up** along the side and parallel to the vehicle. [Figure 2-1]



CAUTION!

Always make sure the vehicle's parking brake is firmly set.

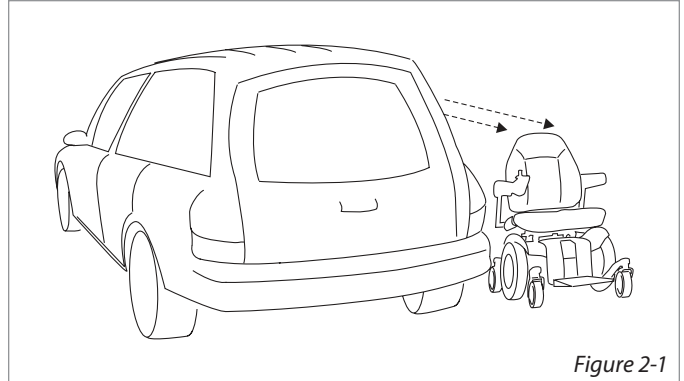

Figure 2-1

2. **Open the vehicle's hatch.** Fold the seat-back of the chair or scooter. [Figure 2-2]



CAUTION!

Keep hands and feet away from the bottom of the chair or scooter as it is being lifted.

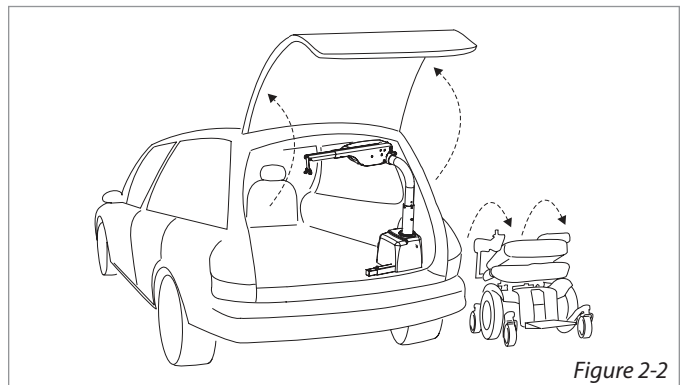

Figure 2-2

3. **Press the 'OUT' button** on the hand controller to rotate the arm outside the vehicle. [Figure 2-3]

NOTE: For the **AL215**, manually rotate the lifting arm outside of the vehicle.



CAUTION!

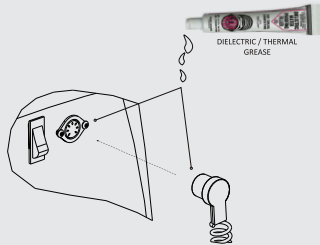

If lift will be exposed to outside elements, add Dielectric Grease or Thermal Paste to both female and male hand control connections.

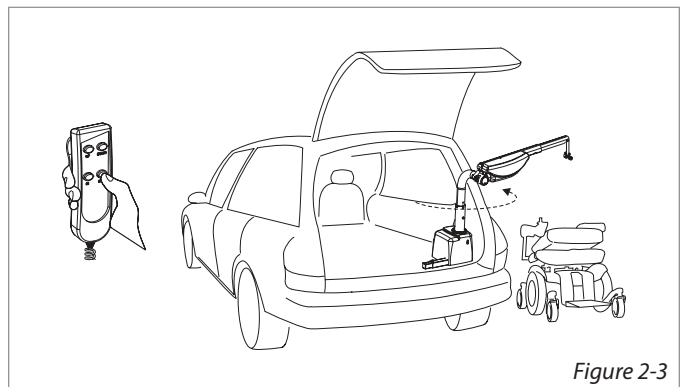

Figure 2-3

NOTE: AL435 series lifts (AL435 / AL435T) have an "EXTEND" button which can be pressed to extend the arm outside, providing more clearance past the vehicle for wider chairs or scooters. [Figure 2-4]

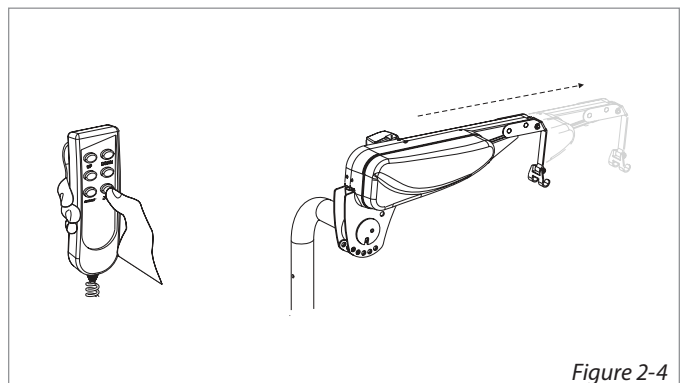

Figure 2-4



CAUTION!

Inspect lifting strap prior to use. **Ensure the lifting strap is secure and that it points straight down.** Failure to do so could result in the chair or scooter swinging, causing damage to operator, chair or vehicle.

4. **When the lift has cleared the vehicle,** press the "DOWN" button to lower the strap.

Attach the docking device supplied with your lift. Attach the strap hook to the docking device. [Figure 3-1]

5. **Press the "UP" button** to begin raising the power chair or scooter. [Figure 3-2]

NOTE: On **AL435** series lifts, you can press the `RETRACT` button to shrink the radius for rotating into the vehicle. This is especially helpful for wider chairs or scooters and for narrower rear vehicle openings. [Figures 3-3]

6. **When the chair is raised enough to clear the bumper/threshold,** rotate the chair or scooter into the vehicle by pressing the "IN" button. [Figure 3-4]

NOTE: For the **AL215** manually rotate the lifting arm inside the vehicle.

7. **When the chair or scooter is fully inside the cargo area,** press "DOWN" until the chair or scooter is placed firmly on the floor.

Leave some tension on the strap during transport to eliminate movement of the chair or docking device.

8. **To unload, reverse the process.**

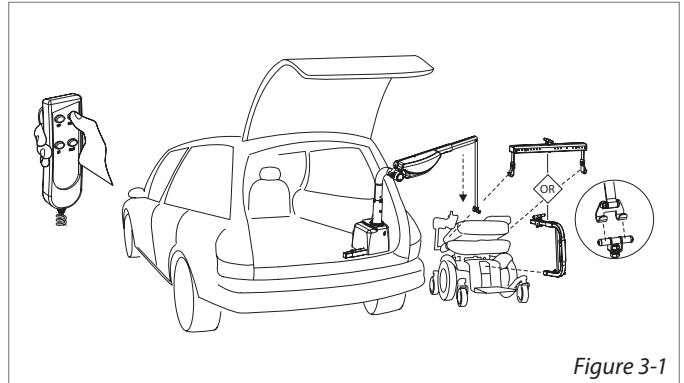

Figure 3-1

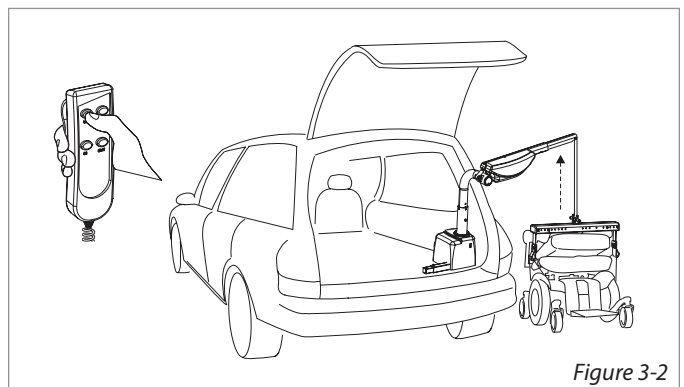

Figure 3-2

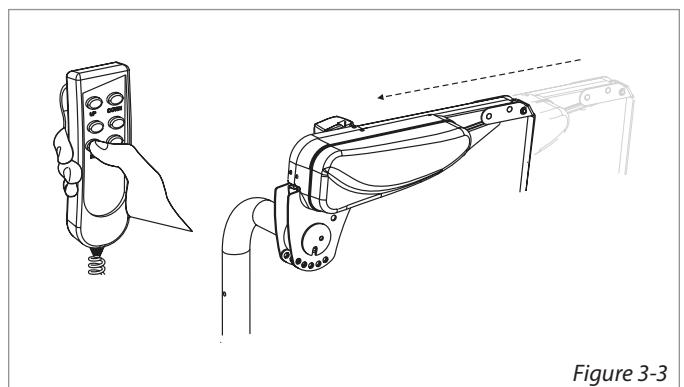

Figure 3-3

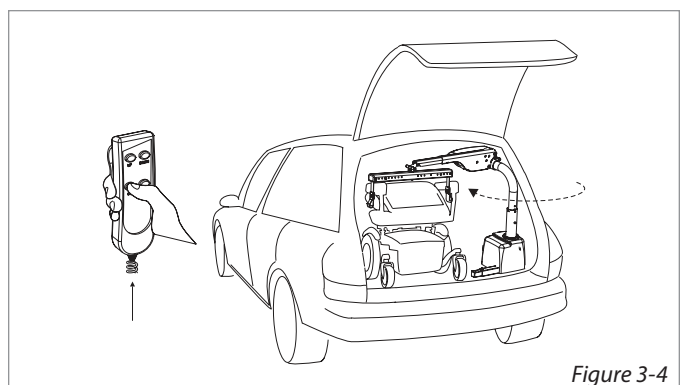

Figure 3-4

OWNER OPERATING YOUR LIFT

When the lift is not being used, press the UP button to run the strap up and keep the hook from swinging. [Figures 4-1 thru 4-3]

NOTE: The **AL215** is manually rotated and does not have a lock to keep it from rotating. In order to prevent it from moving when not in use, we recommend that the strap be run down by holding the DOWN button until the hook has reached the gusset nearest the side wall of the vehicle. Latch the hook on the gusset and press the UP button until the strap is taut, as shown for passenger side applications. [Figure 4-4]

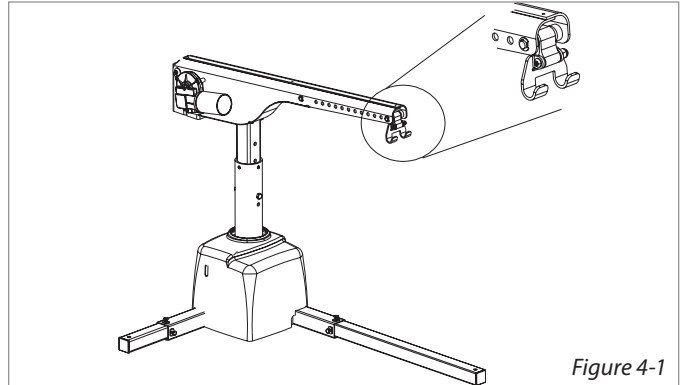

Figure 4-1

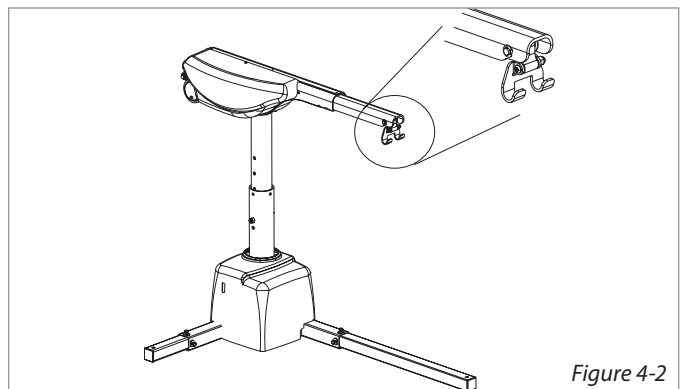

Figure 4-2

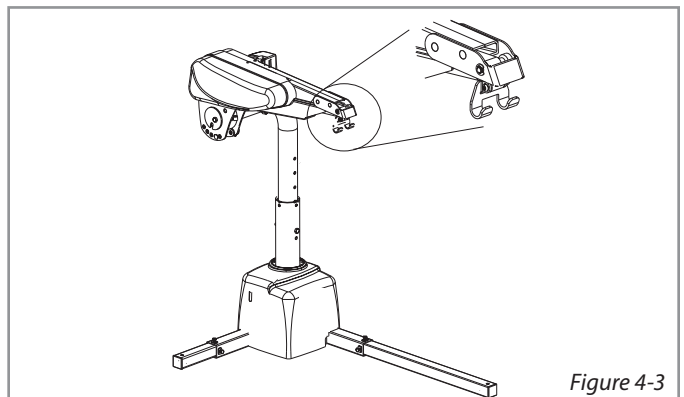

Figure 4-3

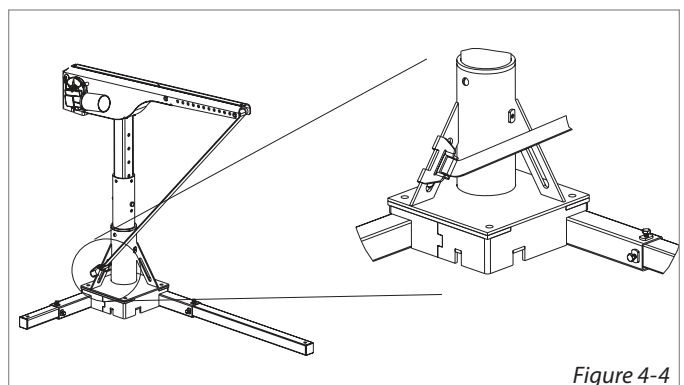

Figure 4-4



CAUTION!

Always hook the strap to the gusset and run taut when **AL215** is not in use.



CAUTION!

Tighten the strap only enough to prohibit the lift from rotating. Over-tightening may cause damage to the strap and/or lift.

SAFETY



DO NOT operate this lift until your dealer has satisfactorily instructed you in its proper operation.



Check regularly before use for any worn, loose, or damaged parts of the lift. [Figure 5-1]

Although your lift is designed and engineered for years of trouble-free use, regular use may result in some parts becoming loose or worn.

- If you notice any problems, **DO NOT USE THE LIFT!** Contact your mobility dealer or installer for repairs or have the strap replaced immediately.
- Use your Inside Lift only for loading and unloading the power chairs and scooters for which it is designed.
- If your particular application (vehicle & chair/scooter) changes, for example, if you buy a new car or change your power chair or scooter, consult your dealer or installer since the original equipment may not configure in the same way.
- **DO NOT** add to or modify any part of the lift system without first consulting the lift manufacturer the action will void the warranty.



WARNING

ALWAYS CHECK THE LIFTING STRAP BEFORE EACH USE FOR DAMAGE OR WEAR

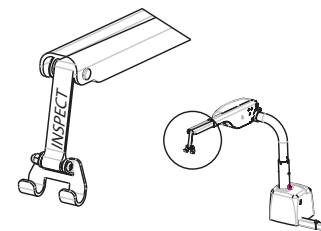

Figure 5-1



CAUTION!

- Ensure the lifting strap is secure and taut when attaching the strap hook to your chair or scooter. Make sure the strap points straight down before lifting. Failure to do so could result in the chair or scooter swinging toward the operator or vehicle, causing damage.
- Avoid having hands and feet under the chair / scooter as it is loaded or unloaded.
- Stop lifting before the strap hook contacts the strap roller or frame. Contact will damage the lift. [Figure 5-2] A properly adjusted lift will avoid contact.

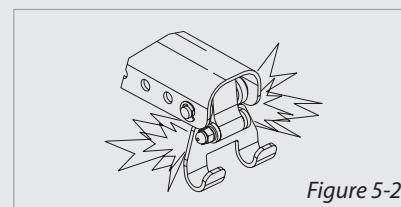

Figure 5-2

- Ensure the chair / scooter is firmly sitting on the floor of the vehicle and not suspended by the lift during transportation. If the chair / scooter is not firmly on the floor, it may move during transport causing damage to the lift, vehicle, chair / scooter, or passengers.

MAINTENANCE

Your Inside Lift has been designed and engineered to be as trouble-free as possible. But as with any mechanical device, it requires regular care while owning and using it.

ALWAYS check the lifting strap before use and while using the lift. If any wear or damage is noticed **DO NOT USE THE LIFT!** Contact the dealer or installer for repair. Failure to do so may result in serious injury or damage.

Schedule a preventative maintenance inspection with your dealer at least once a year on motors, lift frame, wiring harnesses, and all moving parts.

Check for paint chips and touch up any bare metal with a good gloss black enamel or lacquer to inhibit rust. This may be necessary more frequently if the lift is subjected to salt air or road salt.

Store hand control units inside the vehicle whenever possible. If the lift is installed in the back of a pickup truck, unplug the hand control after each use and store it inside the cab. Submerging the hand control in water may cause it to fail.

READ & UNDERSTAND THIS MANUAL PRIOR TO INSTALLATION OR OPERATION

Having an overall understanding of the lift and proper installation techniques will help you save time, energy and avoid possible injury.

If you do not understand any portion of installation or operation, please consult our technical service department or authorized mobility dealer. Do not attempt to install or use this lift with any hesitation or question. Serious injury or damage can result if proper procedures are not followed. We strongly recommend having a certified dealer install the lift, configure the docking device and instruct the user on correct operation as well as establish a Safety and Maintenance Schedule.

NOTE: The components of this lift are packaged as separate units that should be lifted out and installed individually.



WARNING!

DO NOT attempt to pick up the entire lift box from the ground; **DO NOT** try to put the lift in or take out of a vehicle alone.



INSTALLATION OVERVIEW

1. Trial Fit for Base Mounting Location

To install the lift, you'll most likely need to drill three holes in the vehicle's floor. Do not drill until you simulate the lift's range of motion inside the vehicle. Also simulate the object to be loaded. Determine an accurate location for the lift while maximizing the remaining cargo area. [Figure 8-1]

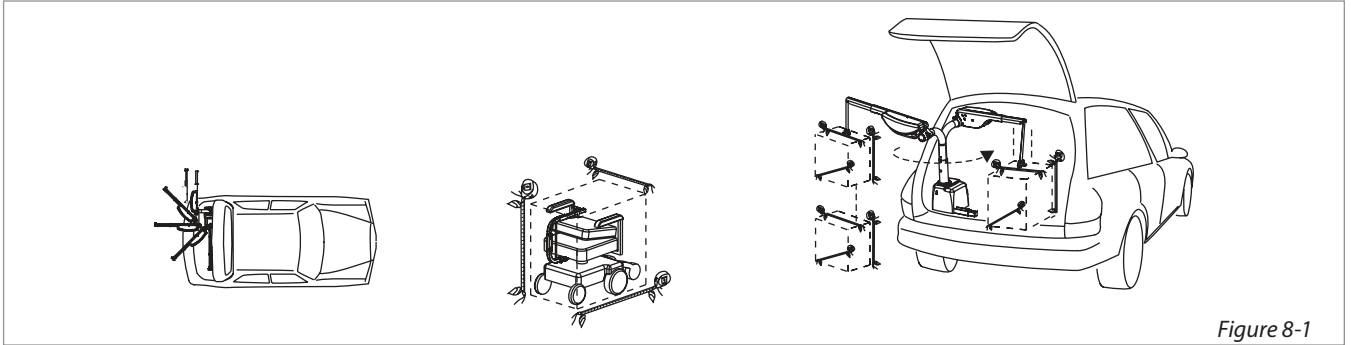

Figure 8-1

2. Vehicle Wiring Harness

Install the vehicle wiring harness first, power will be available to move the lift, making installation easier. [Figure 8-2]

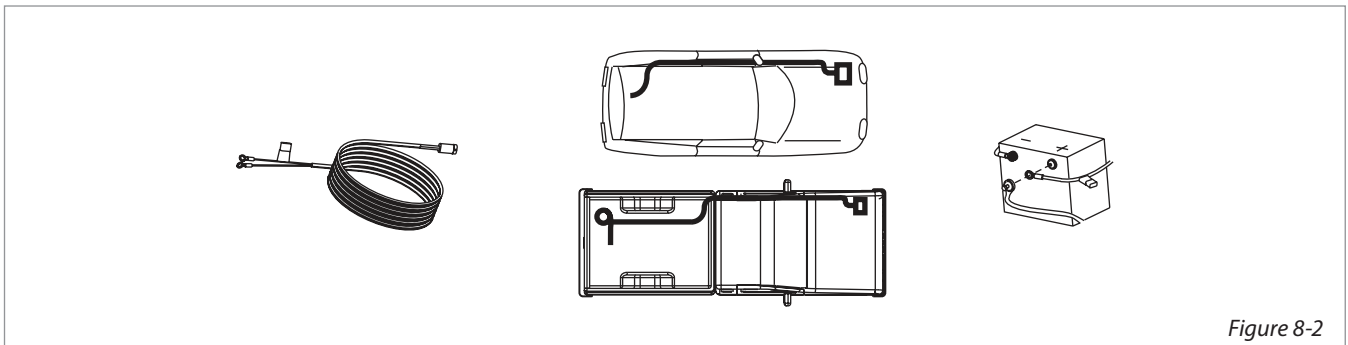

Figure 8-2

3. Installing Lift Components

You'll install the base adapter in the chosen location based on the trial fit procedure. Install base of lift onto the base adapter, then install the lifting arm. [Figure 8-3]

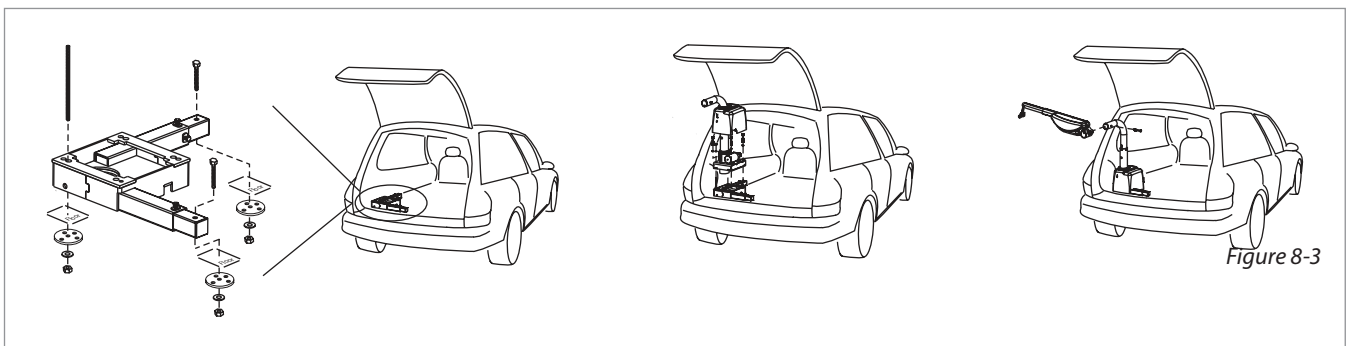

Figure 8-3

TOOLS REQUIRED

Installations may vary to some degree, but below are the basic tools to have on hand for an Inside Lift installation.



SAE SOCKETS

7/16"
1/2"
9/16"
3/4"



SAE WRENCHES

7/16"
1/2"
9/16"
3/4"



SAE ALLEN WRENCHES

5/32"
1/8"
3/16"
5/16"
3/8"



WIRE
CUTTERS



NEEDLE NOSE
PLIERS



#2 FLAT HEAD
SCREWDRIVER



#2 PHILLIPS HEAD
SCREWDRIVER



SMALL HACKSAW



ELECTRIC DRILL



MARKING IMPLEMENT



TAPE MEASURE



DRILL BITS

PILOT DRILL BIT
3/8" DRILL BIT
9/16" DRILL BIT



METAL FILE

UNPACKING THE LIFT

Check the box contents. Review each part against the packaging checklist to ensure that all parts have been included.

If any parts are missing or damaged, immediately contact the dealer who sold the lift. Do not attempt to install or use a lift that has missing or damaged parts.

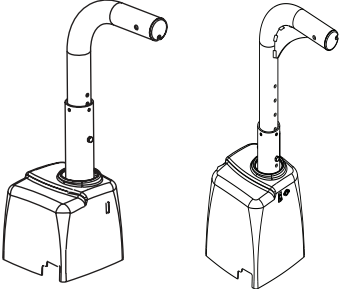
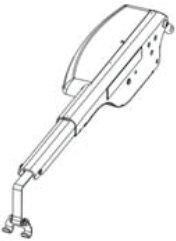
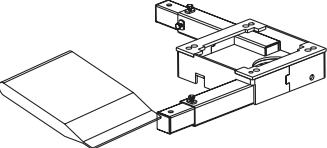
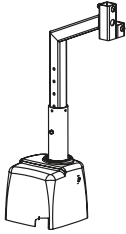
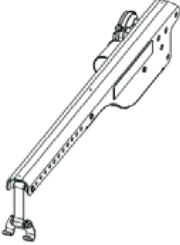
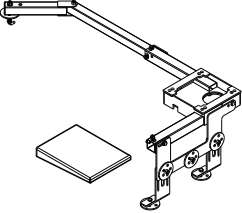
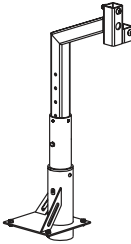
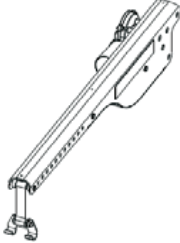
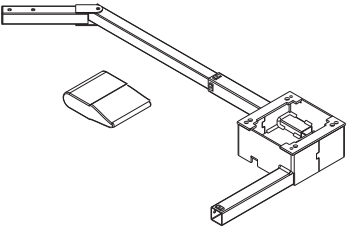
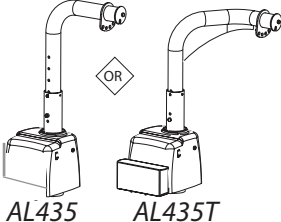
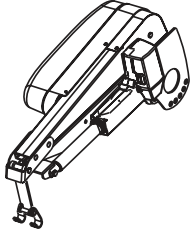
Base Adapters & Hardware Pack		Base Assembly & Offset Post	Arm Assembly
<p>The base adapter for your specific application is included in the lift package.</p>	<p>AL425/ AL425HD</p>	 <p>AL425 AL425HD</p>	
<p>BA00 Standard Used on any flat surface</p> 	<p>AL225</p>		
<p>BA01R1 Stow 'n Go Used with folding seats</p> 	<p>AL215</p>		
<p>BA22 Heavy Duty Used on flat surface</p> 	<p>AL435 or AL435T</p>	 <p>AL435 OR AL435T</p>	

WIRING THE VEHICLE

Improper wiring is the #1 cause of problems in operating a vehicle lift. Follow the wiring instructions carefully.

The vehicle wiring harness is located in the hardware pack. The harness is manufactured to comply with SAE J1128 requirements. It is approximately 23 feet long and will accommodate most vehicles.

1. Unwind the wiring harness and lay it flat.

One end of the harness has 2 covered pins. This is the lift end and goes to the rear cargo area where the lift mounts. [Figure 11-1]

The wiring harness is unassembled for easier installation. The end connector is included separately from the harness to enable the installer to run the wire under and through the vehicle with the smallest clearance possible

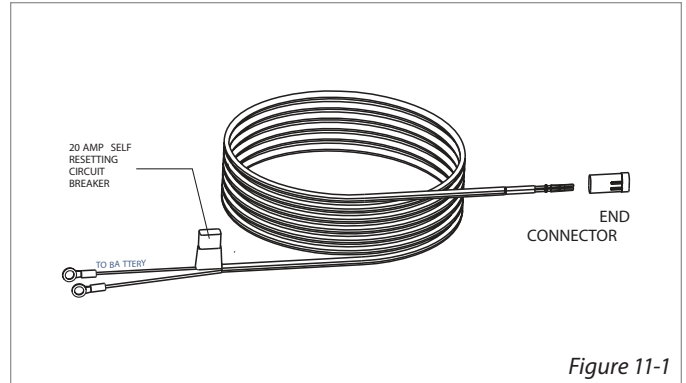

Figure 11-1

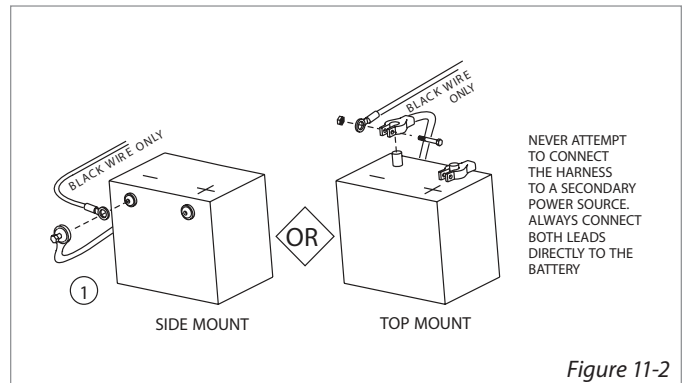

Figure 11-2



DO NOT attach the red wire until the very end of installation.

WARNING!

2. Route the wire harness beginning at the battery. Attach the black wire to the negative terminal on the battery. [Figure 11-2]



DO NOT attach the red wire until the very end of installation.

WARNING!

3. Run the vehicle harness to the rear cargo area/trunk. Run the wire under and through the vehicle whenever possible, gaining entry into the vehicle through the firewall. [Figure 11-3]



DO NOT run wiring where it can be snagged by road debris or near the gas tank.

WARNING!

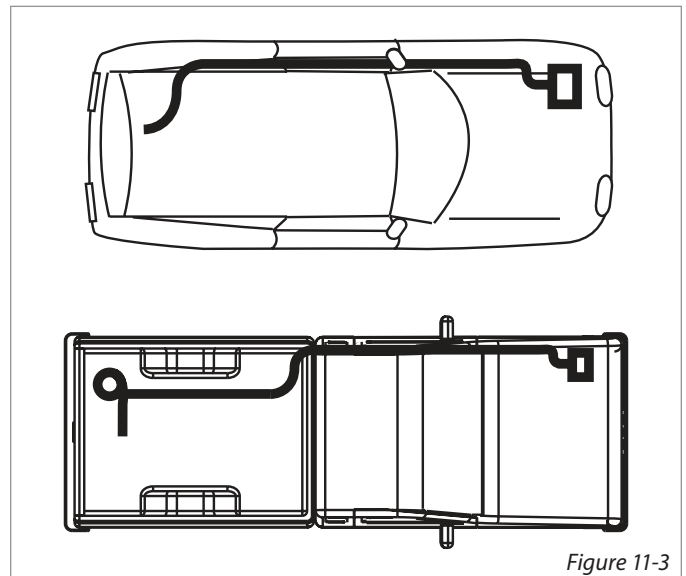

Figure 11-3

IMPORTANT! If the installation requires the wiring harness to run on the underside of the vehicle, route the harness away from the exhaust system, brake lines, fuel lines and gas tank. Avoid pinch points and sharp edges. Avoid locating the harness where it can be snagged by road debris.

INSTALLER INSTALLATION

If you want to run the harness under the vehicle, you will most likely need to drill a hole to get the wire into the rear cargo area/trunk. Use the supplied 3/8 grommet in the hole to protect the wire.

If the harness is too long for the vehicle, coil the excess wire and secure it to the vehicle frame with the supplied cable ties.

DO NOT cut or shorten the harness.

4. **When the harness is through the vehicle, remove the pin's protective tubing.** [Figure 12-1]
5. **Inspect the pin's retaining flanges.** The flanges may have been deformed while being run through the vehicle. These are critical to secure the pins inside the connector. Adjust as needed. [Figure 12-2]
6. **Flip open end connector's hinged retainer.**
 - Insert pins as shown. [Figure 12-3]
 - Verify the wires cannot be pulled out by moderately pulling on the wires.
 - Be sure rubber seals are inside the back of the connector.
 - Close the hinged retainer.
 - Plug connector into lift.
7. **Attach red wire to the positive terminal on the battery.** [Figure 12-4]

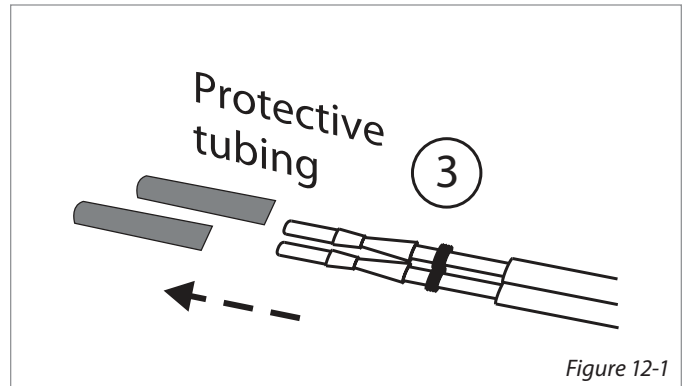

Figure 12-1

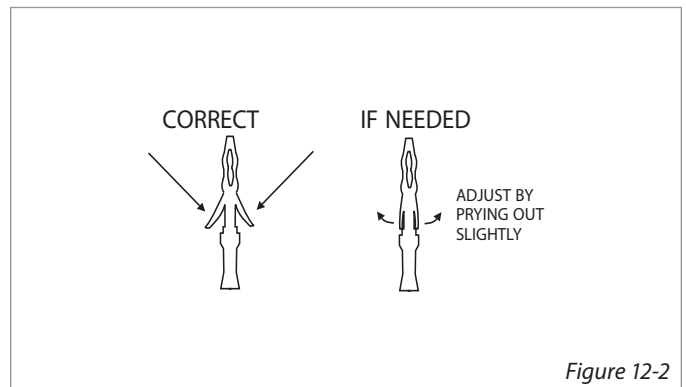

Figure 12-2

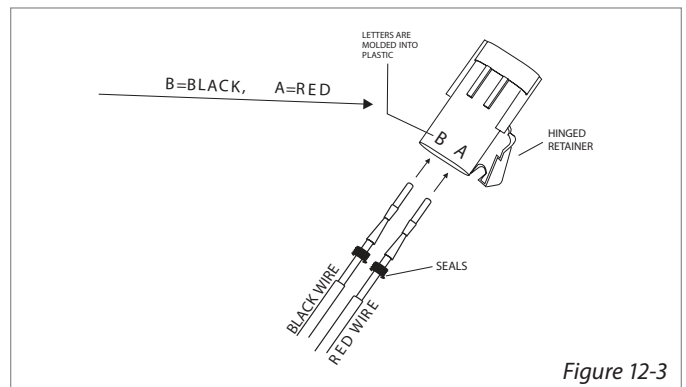

Figure 12-3

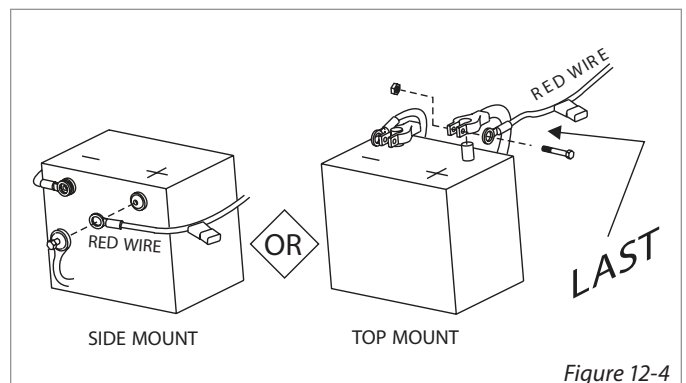

Figure 12-4

TRIAL FIT PROCEDURE

The **AL215, AL225, AL425, AL425HD, AL435, AL435T** require a minimum of three holes to be drilled into the vehicle's floor to secure the base. The positioning is vital to the lift's successful installation and operation.

Before drilling any holes, ensure that the lift can be positioned to permit a full range of motion. [Figure 13-1]

- 1. Place the base in the vehicle's cargo area.**
Shown is passenger-side installation. [Figure 13-2]
Driver's side is identical, but mirrored.
- 2. Fold the chair or scooter's seat back** (or remove seat), preferably with the docking device attached, to roughly observe the chair's transportable dimensions. Measure length, width and height. [Figure 13-3]
- 3. With an assistant, place the lift on top of the base** in the extreme back corner of the cargo space. This will yield the greatest available loading area. Slide the arm onto the post. [Figure 13-4]
- 4. Simulate each of the chair's dimensions** (length, width and height) while running the lift through its full range of motion in and out of the cargo area. [Figure 13-5 Bottom]
- 5. Verify that each of the measurements allows full range of motion** within the cargo area and the opening, mark the three locations to drill. [Figure 13-6]

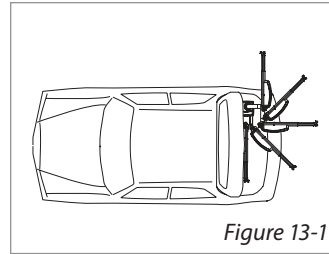

Figure 13-1

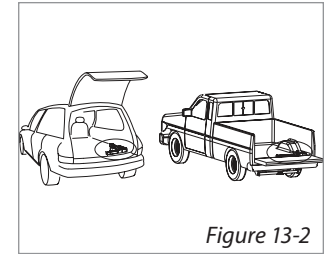

Figure 13-2

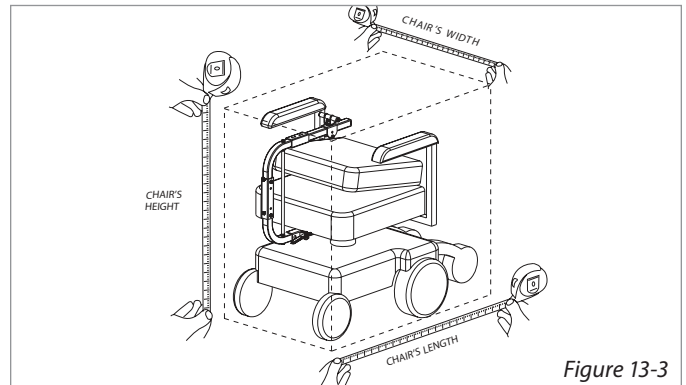

Figure 13-3

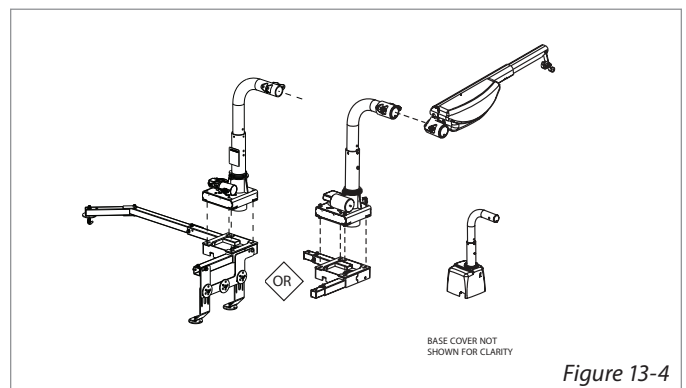

Figure 13-4

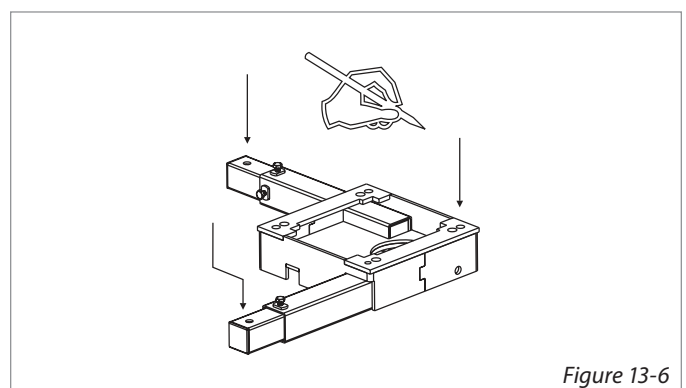

Figure 13-6

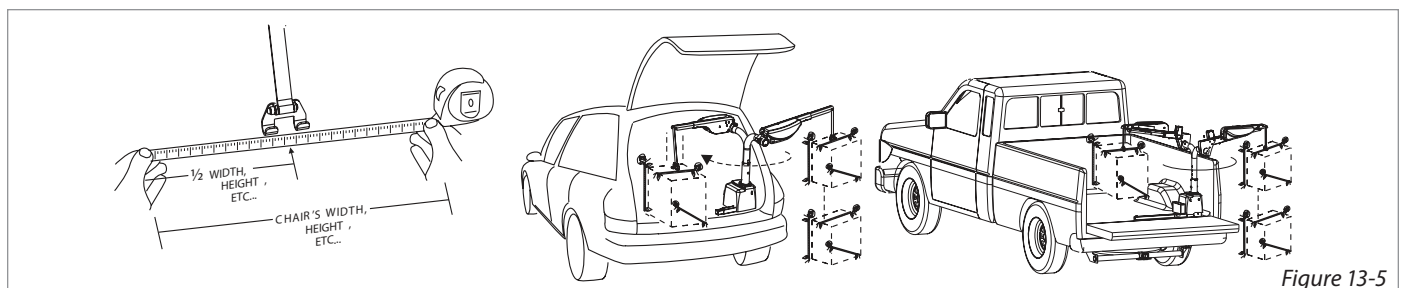

Figure 13-5

BASE INSTALLATION: FLAT FLOOR

After you know the lift position from the trial fit procedure, you are ready to drill three 3/8" holes in the locations you marked.

1. Drill Pilot Holes

- Choose a safe location to drill a single pilot hole from above in one of the three marked locations.
- Look under the vehicle and measure the specified distance from the pilot hole.
- If all is clear in that area continue to drill in remaining locations.
- Inspect all three pilot holes under the vehicle.
- If all clear, drill 3/8" holes in pilot locations.

[Figure 14-1]



Avoid vehicle wiring, fuel lines, fuel tanks, spare tires, etc. when drilling.

CAUTION!

2. Fasten Base

When holes are drilled, fasten base to vehicle floor using supplied hardware in the hardware pack. Be sure to tighten all fasteners. [Figure 14-2]

Special Cases

Storage compartment or well can potentially affect lift placement. Most of these situations can be managed with the help of an All Thread Kit.

[Figure 14-3]

Spare Tire Storage

If the spare tire is stored under the floor, be sure that the base can be bolted through a steel floor or frame.

NOTE: Feed lifting wire through notch of base adapter, then through large hole. See image on page 22.

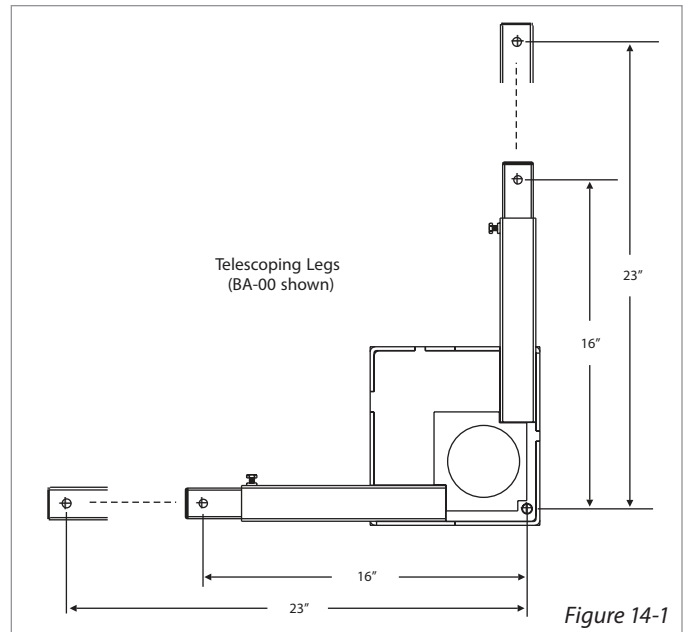

Figure 14-1

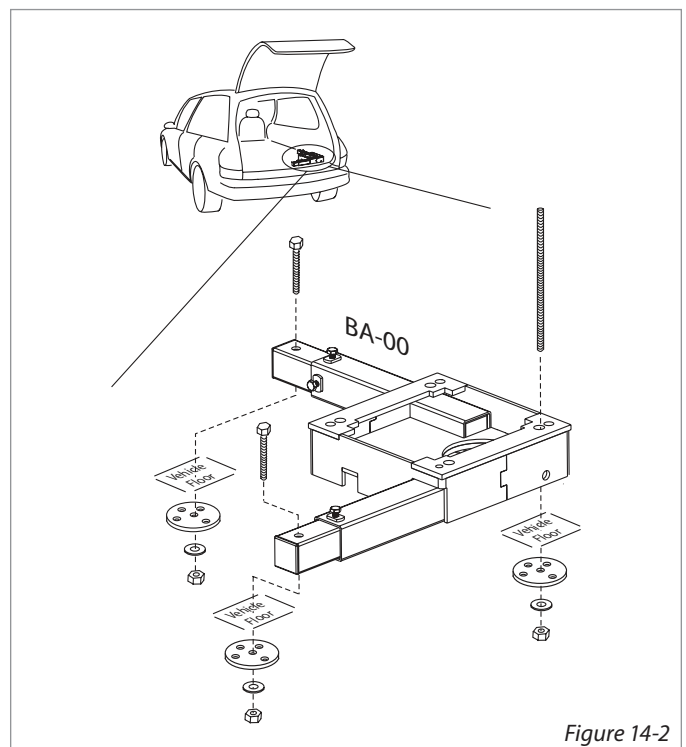

Figure 14-2

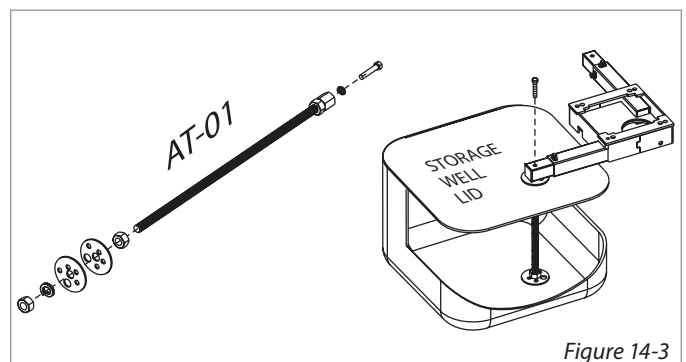

Figure 14-3

BASE INSTALLATION: 3RD ROW FOLDING SEATS

1. **Place vertical joiner on back wall** of seating well corner. [Figure 15-1] Use base as template for position.
2. **Establish height** by having mounting holes show over threshold. [Figure 15-1] Attach joiners, using small screws provided, to lock height. [Figure 15-2]
3. **Preferred Installation.** Mandatory when lifting heavier payloads.
 - Drill two 3/8" holes in floor of well using joiners as template. Fasten 3/8" hardware (x2). [Figure 15-3]
 - **PLUS** Drill three 3/8" holes through back well wall using joiners as template to accept full-threaded 3/8" bolts. [Figure 15-3]

VERIFY THAT ALL MATING SURFACES ARE FLUSH.

4. **Fold third-row seating back into well.** Verify vertical joiner mount holes are above threshold. [Figure 15-4]
5. **Attach vertical joiner to base** using supplied hardware as indicated. [Figure 15-5]
6. **Insert telescoping leg.** Attach articulating leg. Drill, or where possible, use J-hook to seat attachment point and secure leg. [Figure 15-6] **Tighten all fasteners.**

NOTE: Feed lifting wire though notch of base adapter, then through large hole. See image on page 22.

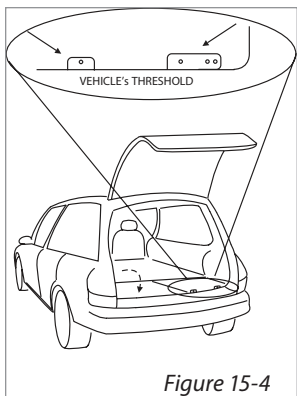

Figure 15-4

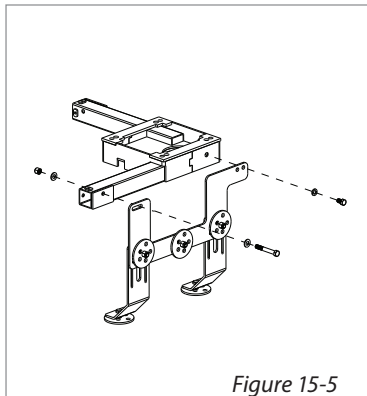

Figure 15-5

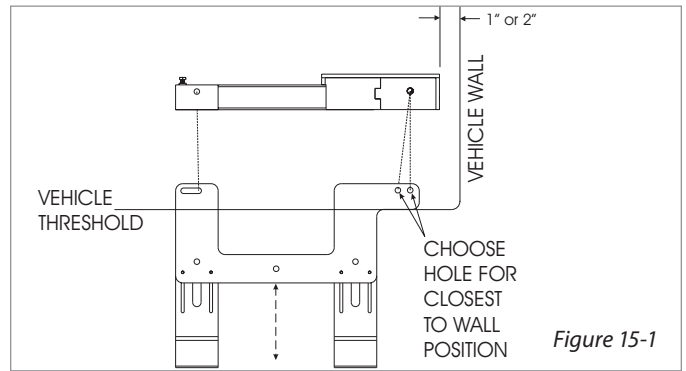

Figure 15-1

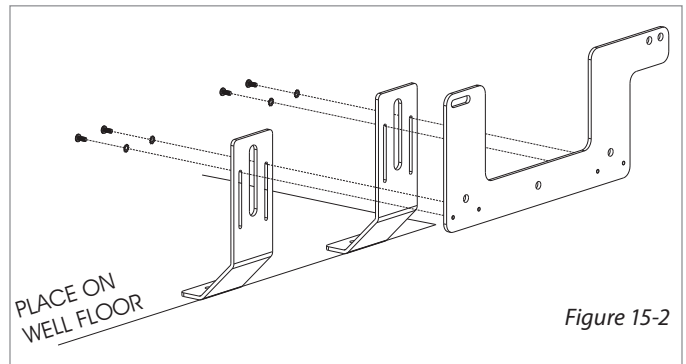

Figure 15-2

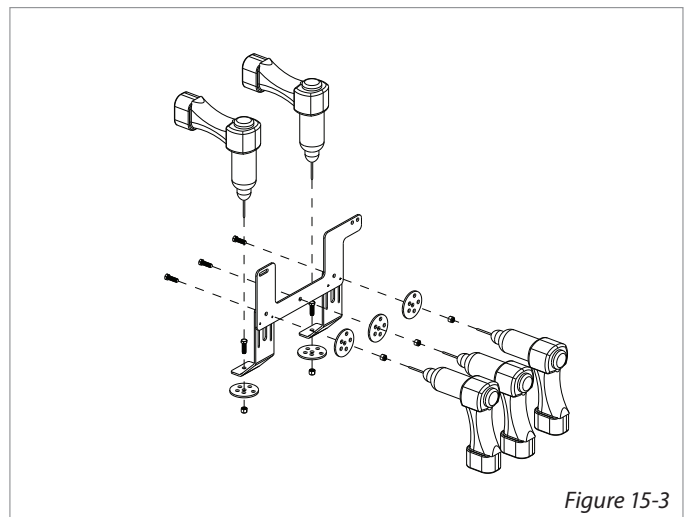

Figure 15-3

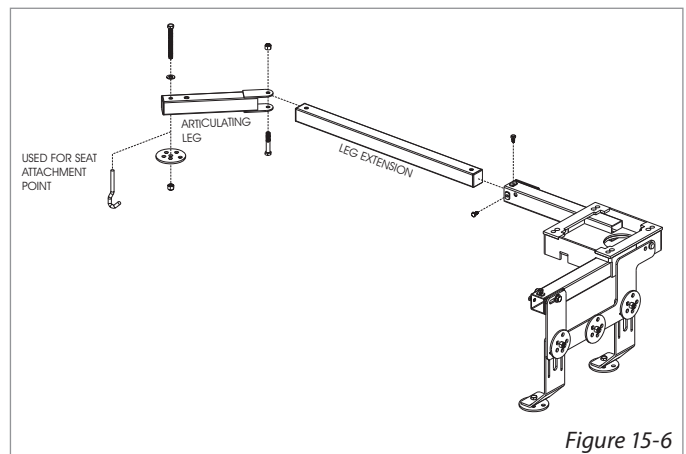
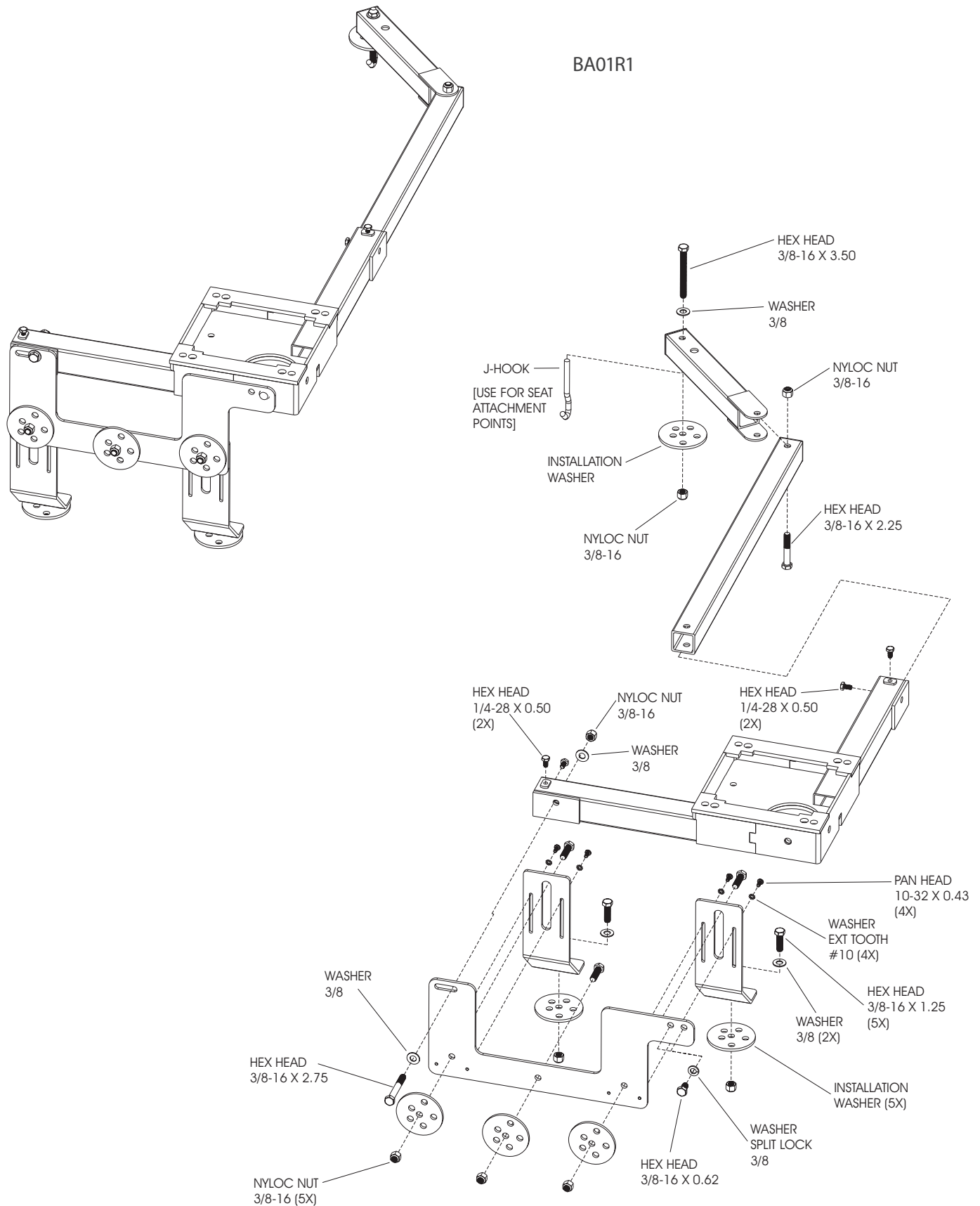

Figure 15-6

EXPLODED VIEW OF ASSEMBLY FOR 3RD ROW INSTALLATION



BASE INSTALLATION: TRUCK BED

- 1. Place base to the nearest corner** of the vehicle, near the tailgate or opening, that the lift is to be mounted. Fasten loose the four Hex Head Bolts, 1/4-28 x 0.50 to the legs of the Base. [Figure 17-1]
- 2. Install the Leg Extensions into Base** and place Anchors (if included) into the Base leg nearest to the Hex Head Bolts; the Long Leg is to run parallel with the bumper. The short leg is to run from rear to front of the vehicle. Attach Articulating Leg (if included) to the short leg. A minimum of 4" of the Leg Extensions are to be within the Base legs. *Tighten by hand, the Hex Head Bolts on the Base to keep the legs from moving. Reposition the Base with legs attached to nearest corner of the vehicle.* [Figure 17-2]

- 3. Recommended practice before drilling.** Position the Base to the nearest the corner, leaving at least 1" of clearance on all sides of the base [Figure 17-3]. With the Base resting in place, use a tape measure to estimate the distance in both directions from an exterior point (EX. Outside body panel) to all potential bolt holes. Repeat this measure underneath the vehicle. [Figure 17-3]

Check the under side of the vehicle for framing, cross-members, bracing, or other nearby thickened structure to mount the Base, Legs, and Anchors. All mounting bolts are to go through a cross-member, framing, and/or thickened structure. [Figure 17-4]. Adjust the Base, Legs, and Anchors as necessary.

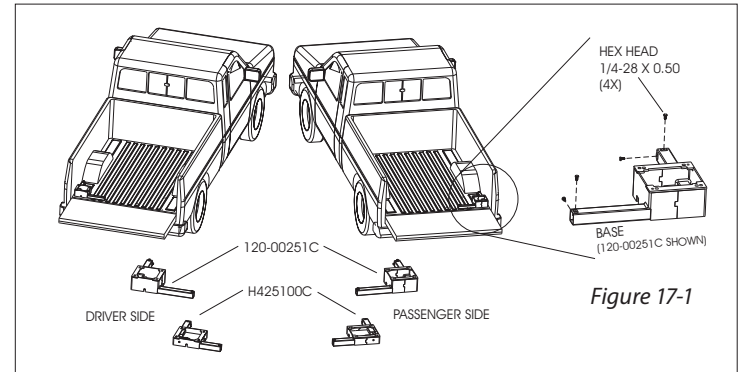

Figure 17-1

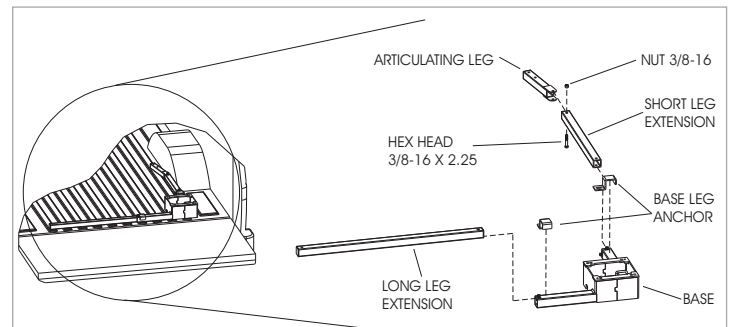

Figure 17-2

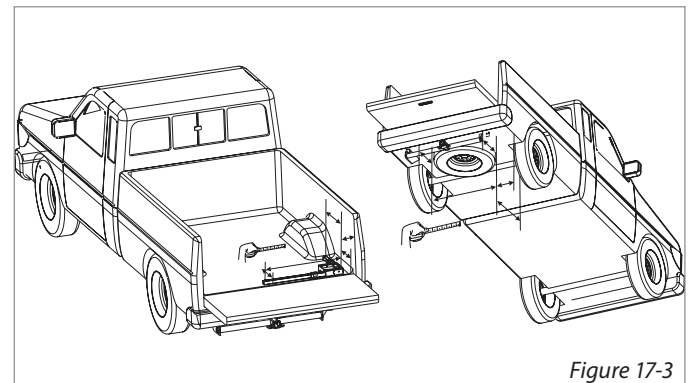

Figure 17-3

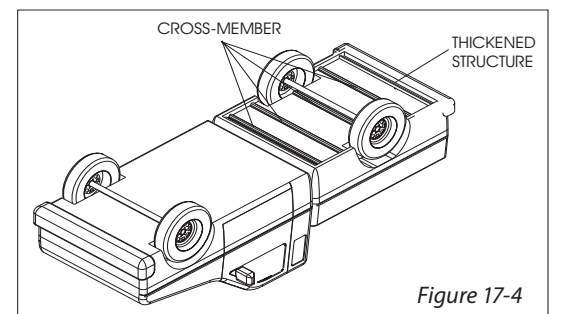

Figure 17-4



CAUTION!

USE EXTREME CAUTION! Examine areas under the vehicle for obstructions or potential hazards such as gas tank, fuel, brake, and electrical lines. Move out of the way or relocate if possible.



CAUTION!

The Base is never to be mounted just to the skin of the vehicle, as it will cause damage to the floor. Always mount to the framing, cross-member, bracing, or thickened material.

BASE INSTALLATION: TRUCK BED

- 4. Double-check and recheck potential hole positions** again before drilling pilot holes. [Figure 18-1] With a center punch or marking device, mark the locations to be drilled. Remove the Base, Legs, and Anchors. Check that the marked locations are in the desired locations. Drill the pilot holes through the marked locations using the 1/8" drill bit. [Fig. 18.2] Be sure to drill straight down, otherwise, fasteners will not fit properly. [Figure 18-3]

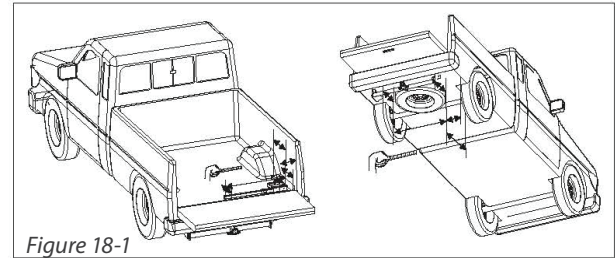

Figure 18-1

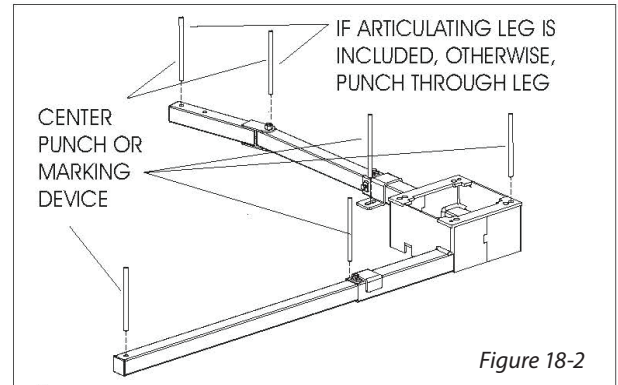

Figure 18-2

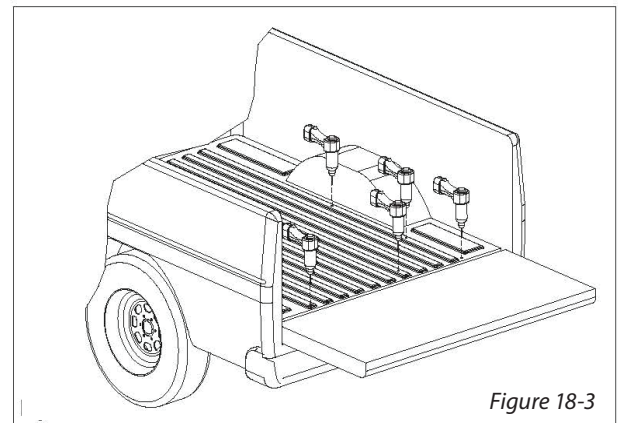
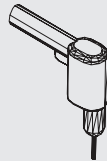

Figure 18-3



WARNING!

Avoid Gas Tank Fuel / Brake / Electrical Lines



CAUTION!

If incorporating the frame is impossible, large plates (not supplied) may need to be used to spread the force and keep the truck bed from distorting. Call the technical service department for further explanation.

- 5. Finish drilling** by making 3/8" holes through the truck bed and when possible, through the frame of the truck in the locations shown. [Figure 18-3]
- 6. Place the Base, Legs, and Anchors back to their locations in the vehicle and fasten tight (28-30 ft.lbs)** with the supplied hardware. Be sure to place all fasteners into the correct locations before tightening [Fig. 18-4]. If included, use the Bed Washers if mounting between the ribs of the truck bed and legs or underneath as additional support.

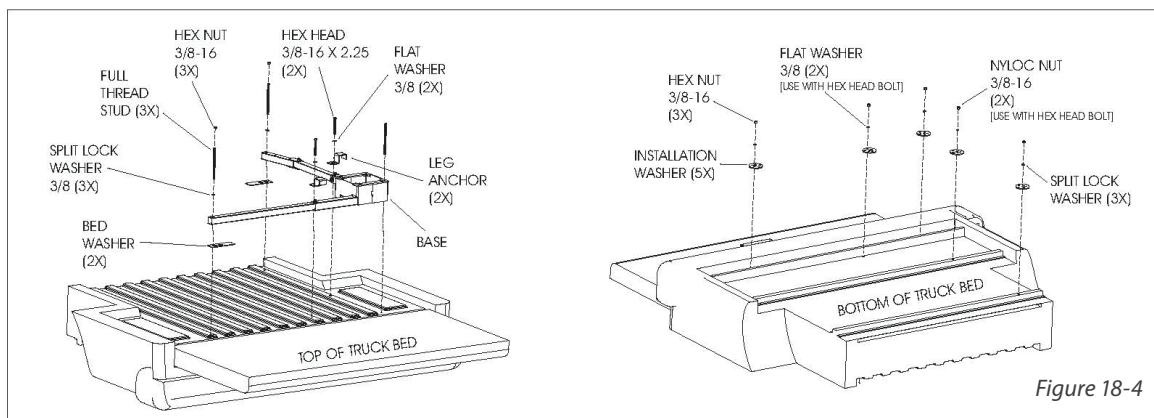
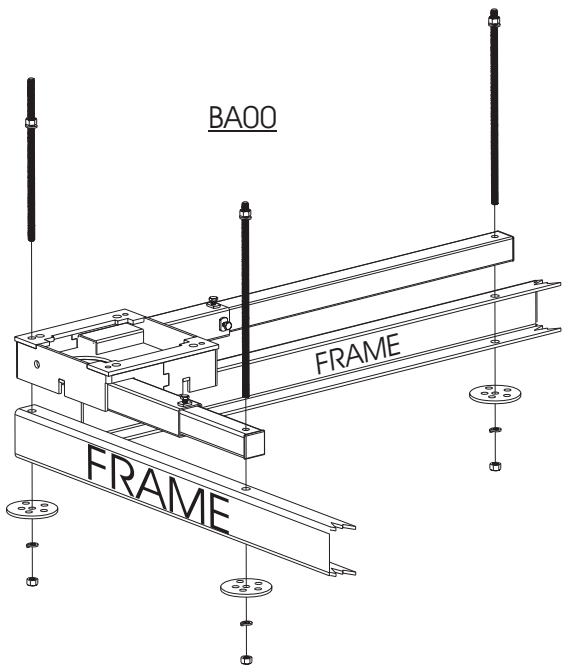

Figure 18-4

INSTALLER INSTALLATION

Where ever possible, incorporate the frame rails or cross-members of the vehicle. This is a requirement when lifting heavier chairs and scooters.



CAUTION

If incorporating the frame or cross-member is impossible, large plates (not supplied) may need to be used to spread the force and keep the vehicle flooring from distorting. Call the technical service department for further explanation.

BA00-I

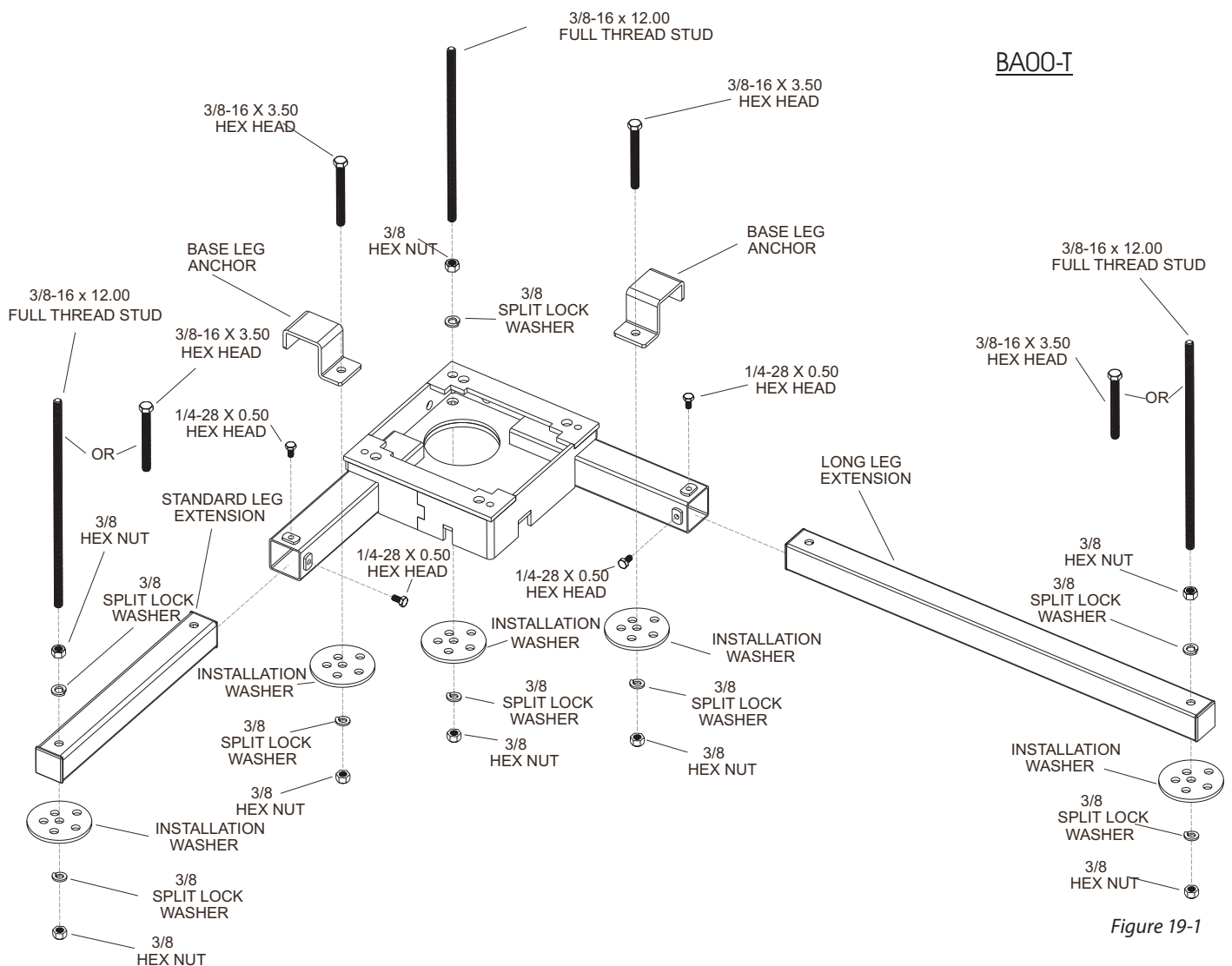

Figure 19-1

INSTALLER INSTALLATION

Where ever possible, incorporate the frame rails or cross-members of the vehicle. This is a requirement when lifting heavier chairs and scooters.



If incorporating the frame or cross-member is impossible, large plates (not supplied) may need to be used to spread the force and keep the vehicle flooring from distorting. Call the technical service department for further explanation.

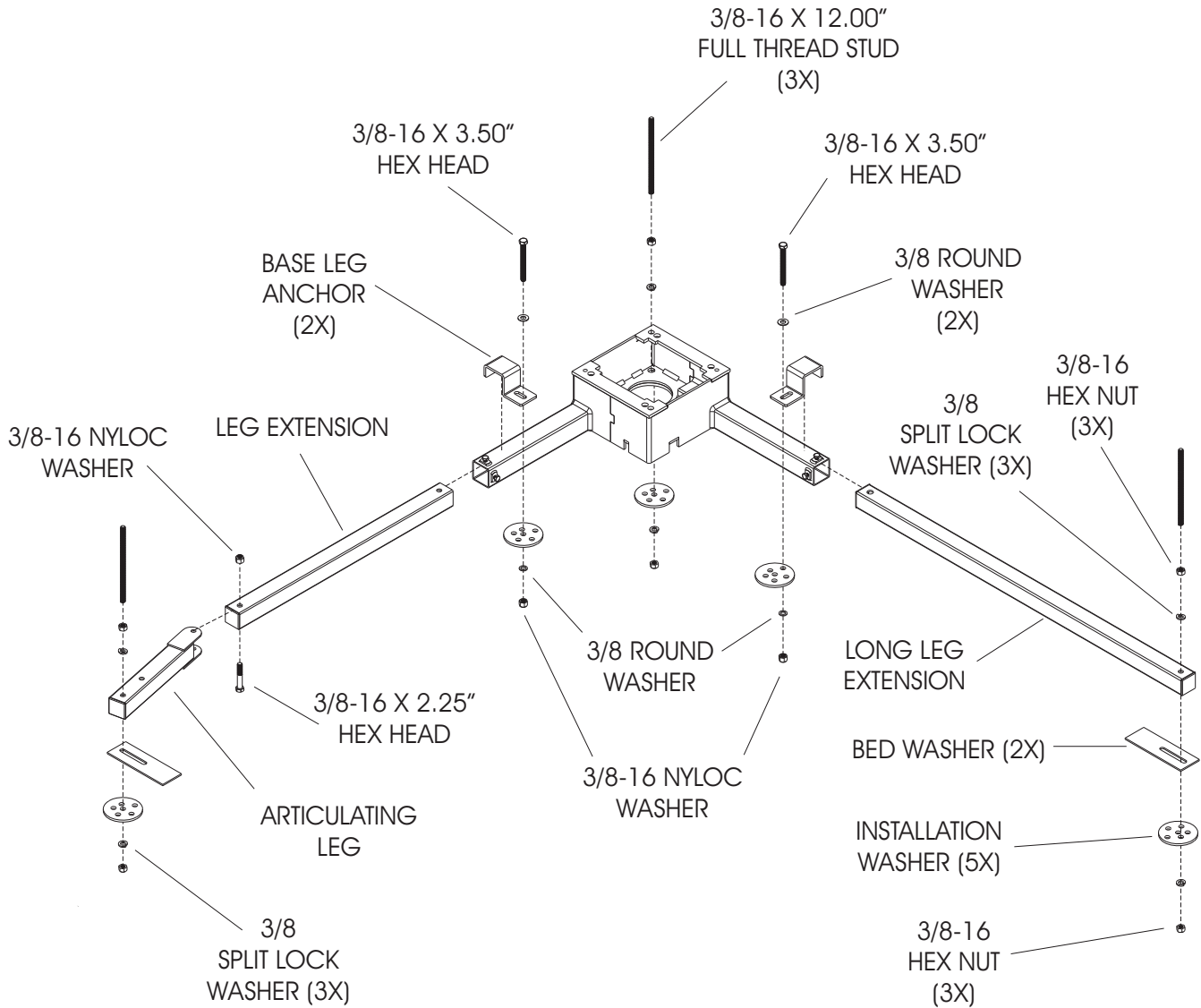
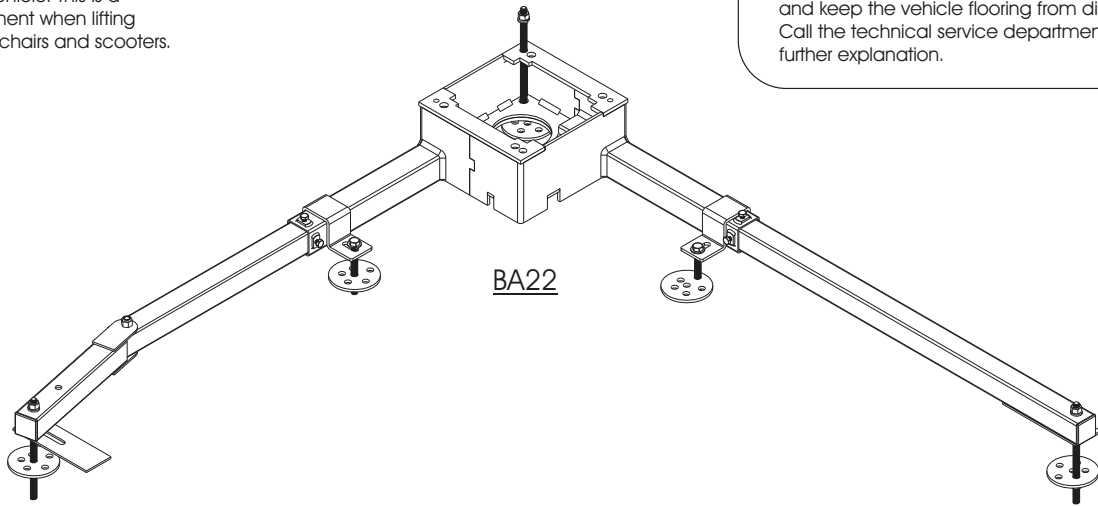

LIFT INSTALLATION

1. **With the Base Adapter fully assembled and fastened to the vehicle**, the Mechanical Stop can be added to the Motor Housing Assembly before being assembled to the Base Adapter, [Figure. 21-1] (only for power rotation lifts).

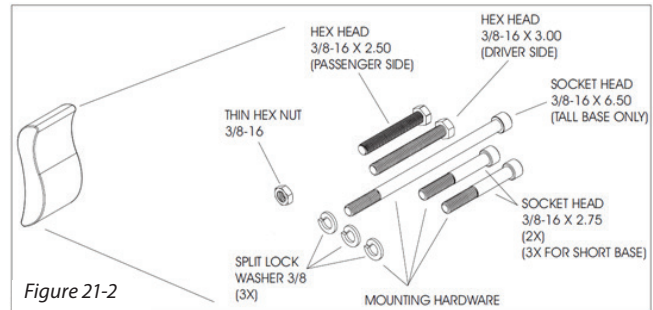
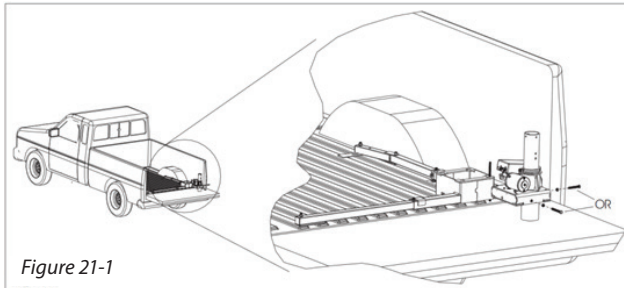

There are two Full Thread Hex Head Bolts and a Thin Hex Nut included with the mounting hardware. Only one of the two bolts will be used depending on whether the installation is for Passenger (3/8-16 x 2.50) or Driver side (3/8-16 x 3.00), [Figure 21-2]

2. **If Passenger Side installation:** the 3/8-16 x 2.50 Full Thread Hex Head Bolt will be used. Thread the Hex Nut to the head of the Bolt, then thread the Bolt all the way into the Motor Housing on the “Flat Side” of the Motor Housing, [Figure 21-3], right side.

If Driver Side installation: the 3/8-16 x 3.00 Full Thread Hex Head Bolt will be used. Thread the Hex Nut to the head of the Bolt, then thread the Bolt all the way into the Motor Housing on the “Curved Side” of the Motor Housing, [Figure. 21-3] left side.

NOTE: Save the unused bolt in case of app postion change.

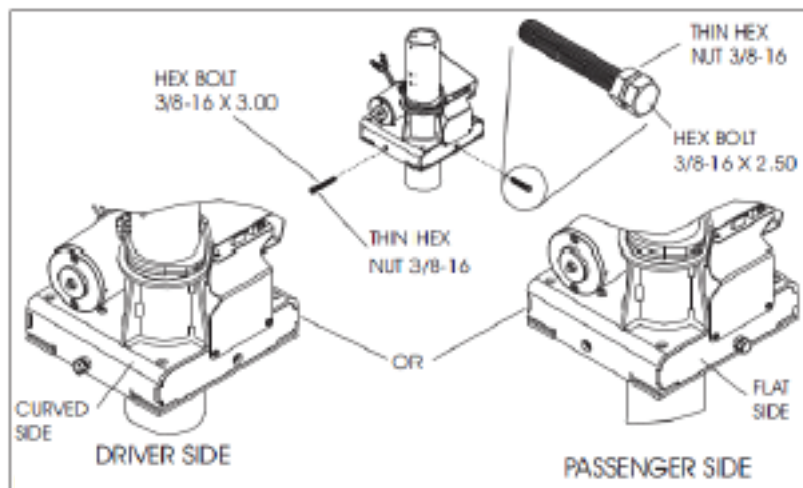
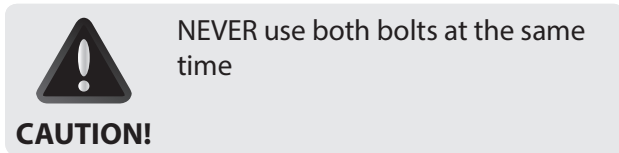

INSTALLER INSTALLATION

- 3. Install Motor Housing to the Base.** Before mounting the Motor Housing to the Base, feed the Lifting Wire (black & white) through the Base, [Figure. 22-1] Mount Motor Housing to Base being sure that the Lifting Wire comes through the Rotational Tube. Fasten tight with the supplied hardware (28-30 ft.lbs) using the 5/16 Allen Wrench and 9/16 Wrenches.

Insert the Post into the Motor Housing Assembly. Be sure to connect the lifting wiring harness within the Post to the harness within the motor Housing. Do not tighten any fasteners. [Figure. 22-3]

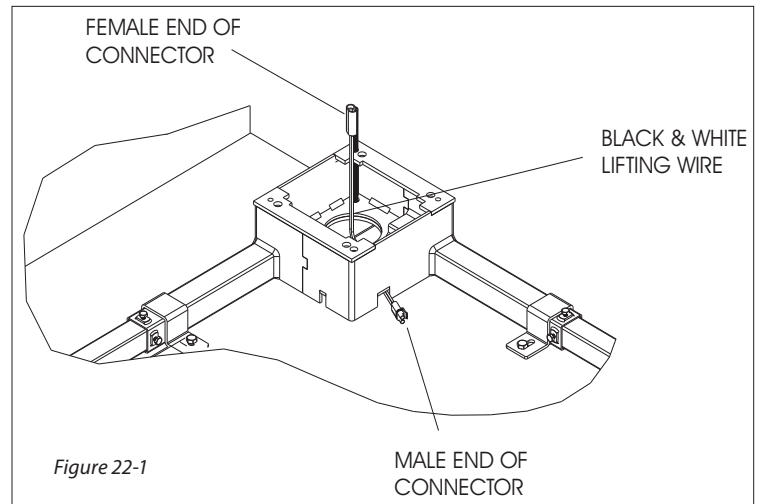

Figure 22-1

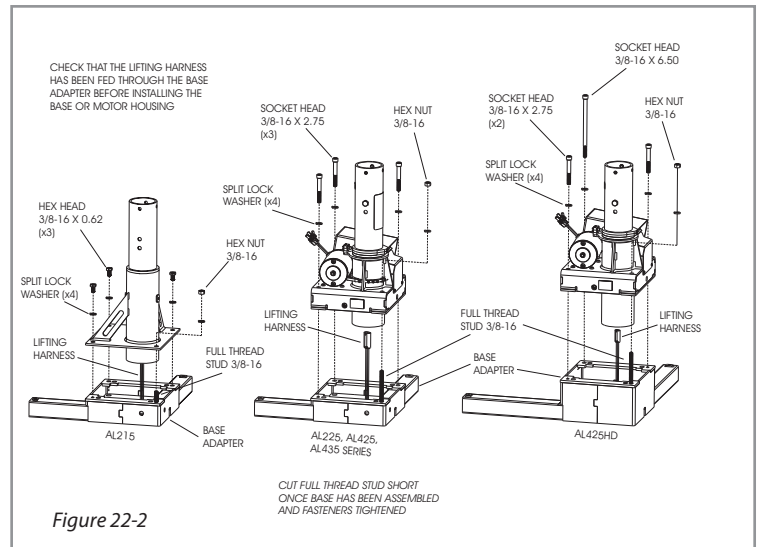

Figure 22-2

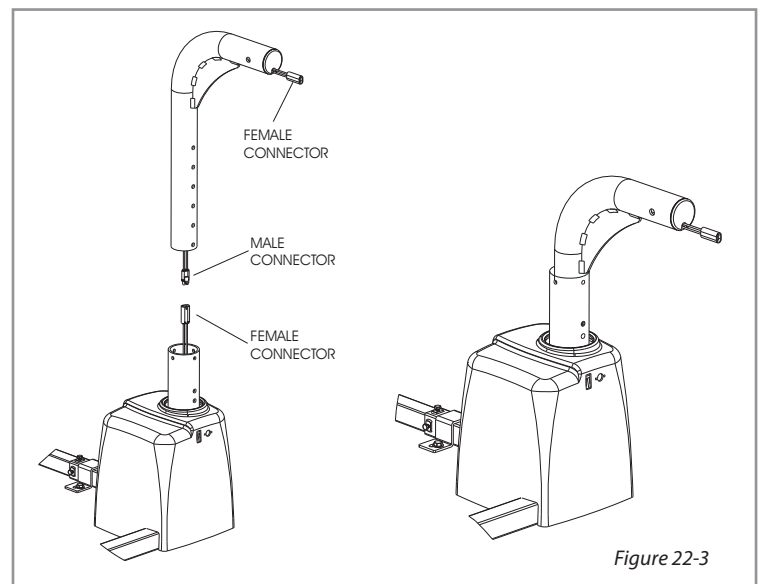
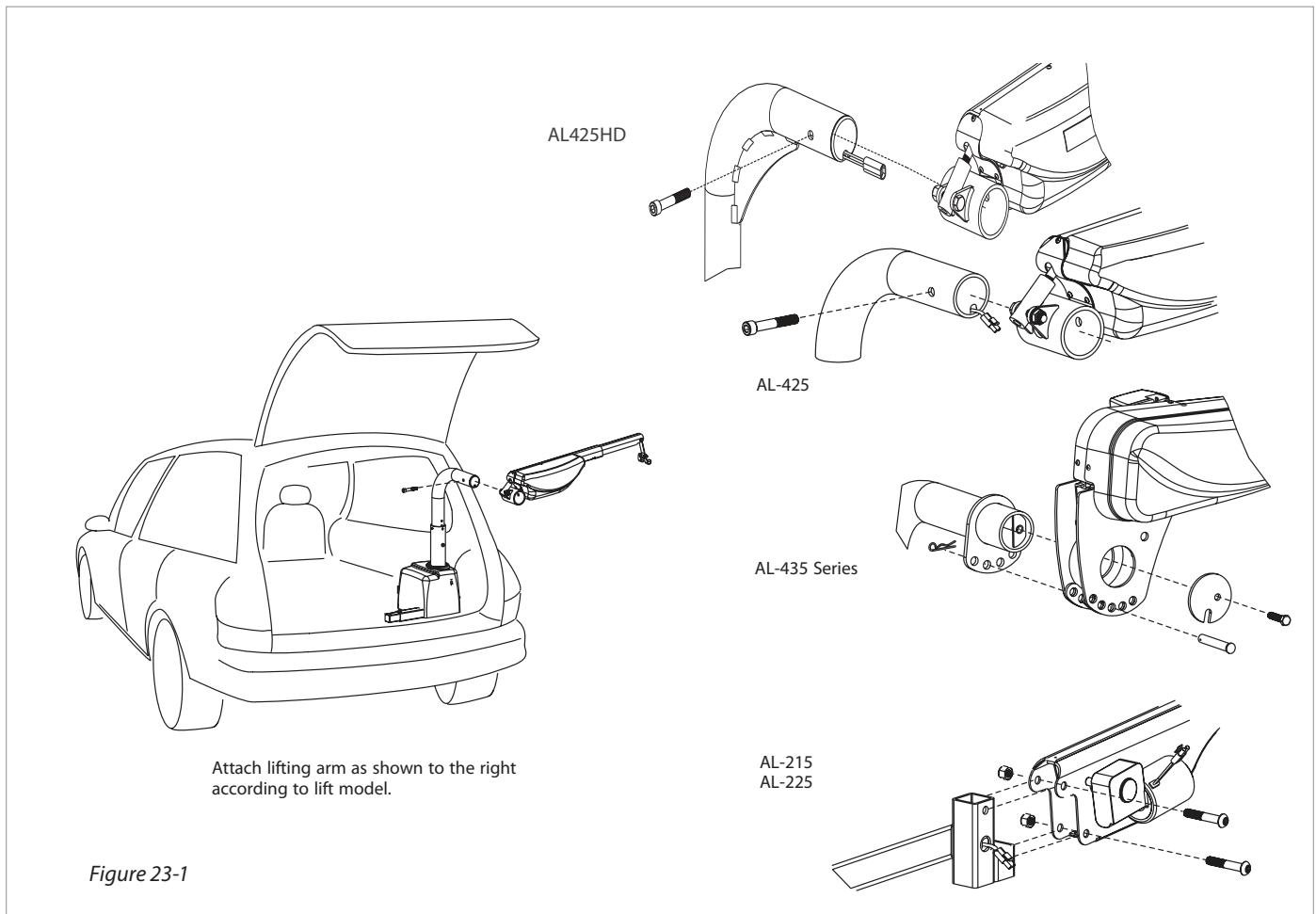
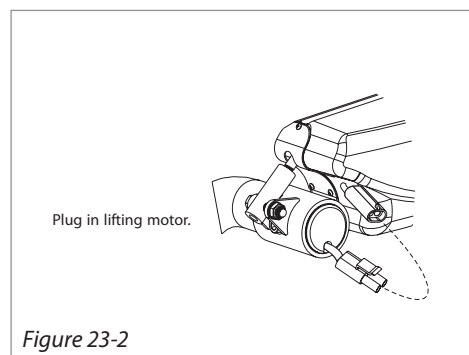

Figure 22-3

1. **Attach lifting arm** as shown according to lift model [Figure 23-1].



2. **Plug in lifting motor.** [Figure 23-2].



ADJUSTMENTS: HEIGHT

AL425 / AL425HD / AL435 / AL435T

- Remove bolt.
- Loosen set screws (x4) [Figure 24-1]
- Slide inner vertical post to desired height.
- Replace bolt and tighten.
- Tighten set screws/ (x4) [Figure 24-2]

AL215 / AL225

- Remove bolt.
- Loosen set screws (x4) [Figure 24-3]
- Slide inner vertical post to desired height.
- Replace bolt and tighten.
- Tighten set screws (x4) [Figure 24-4]

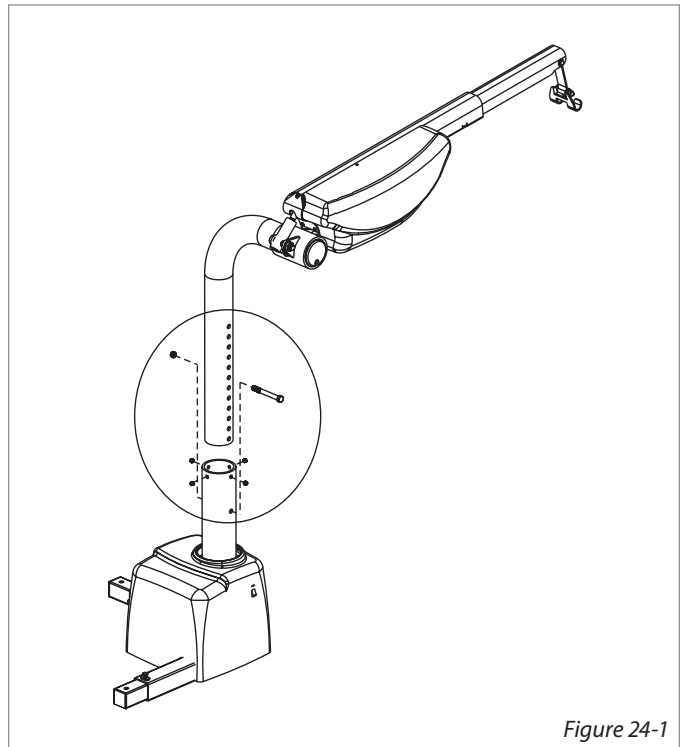

Figure 24-1

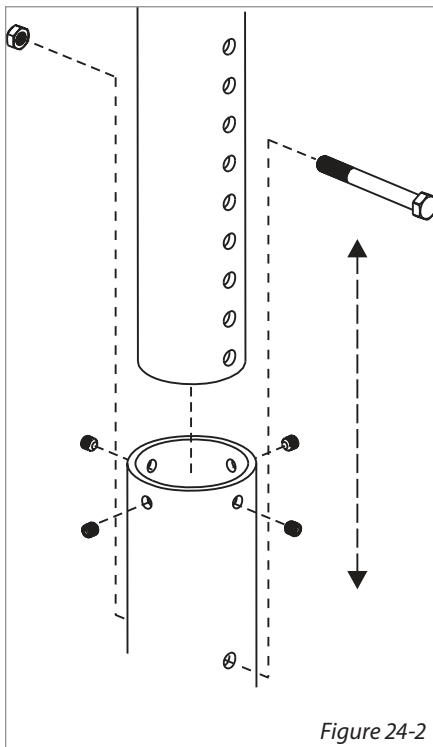

Figure 24-2

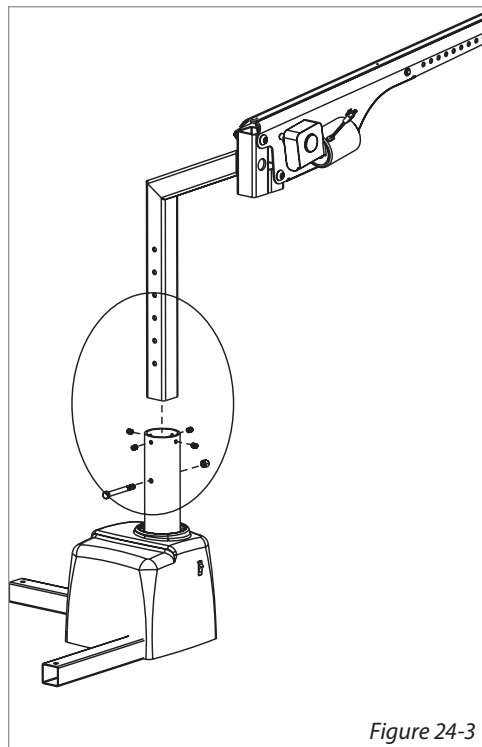

Figure 24-3

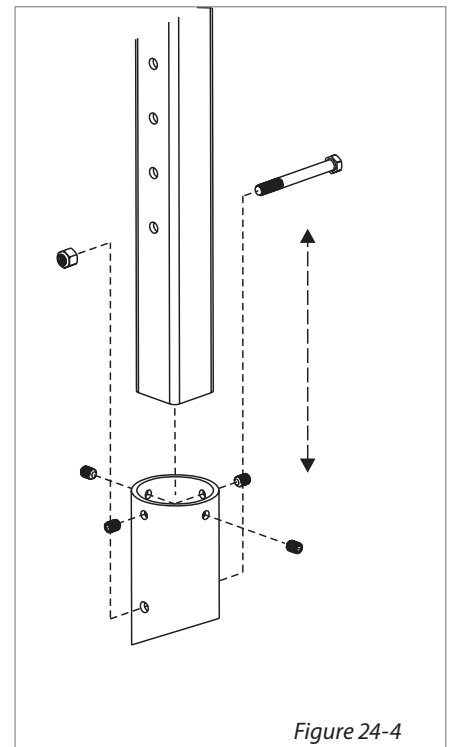

Figure 24-4

ADJUSTMENTS : PITCH

AL425 / AL425HD

- Remove bolt.
- Rotate turnbuckle.
- Replace bolt. [Figure 25-1]

AL435 / AL435T

- Loosen bolt.
- Remove pin.
- Rotate arm to desired pitch.
- Replace pin.
- Tighten bolt. [Figure 25-2]

NOTE: The AL215 and AL225 are manufactured with a 5 degree pre-load so pitch adjustment is not necessary. [Figure 25-3].

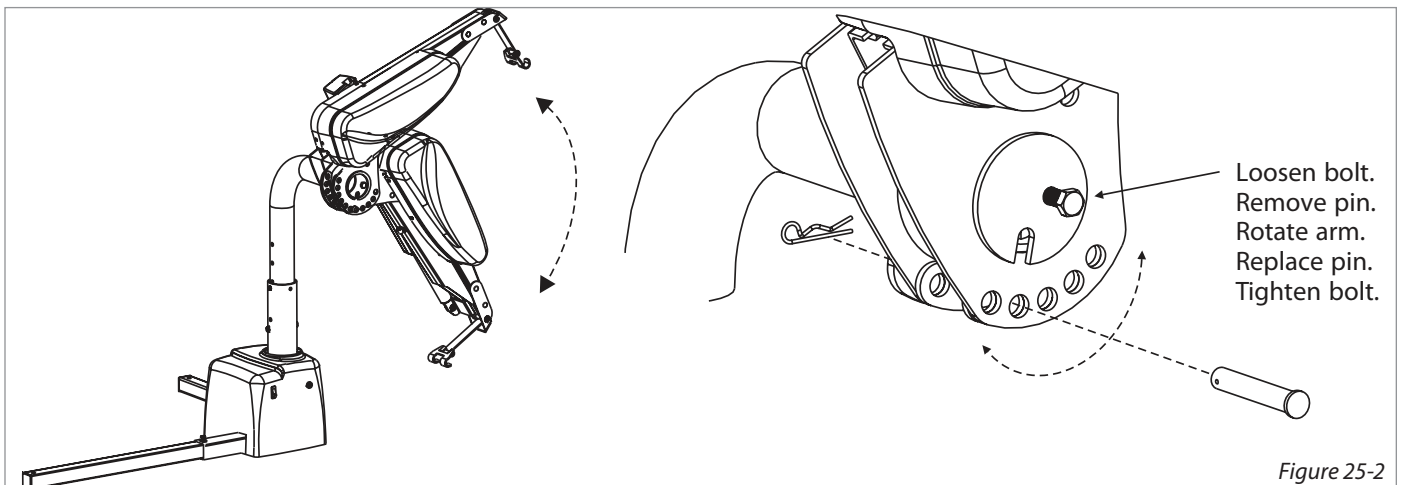
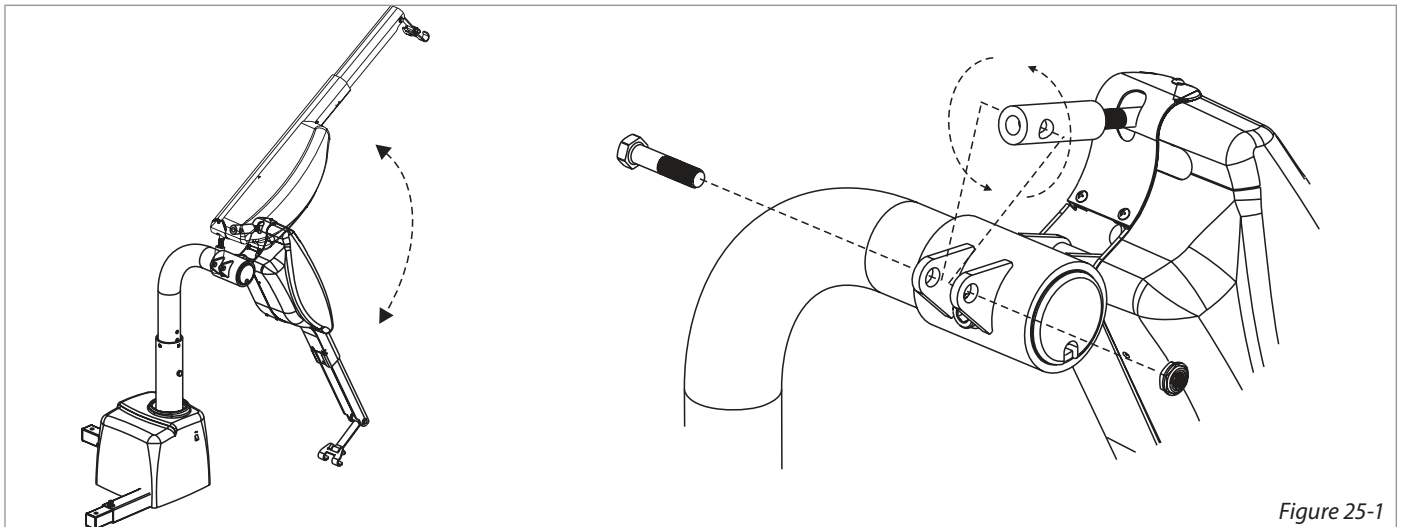
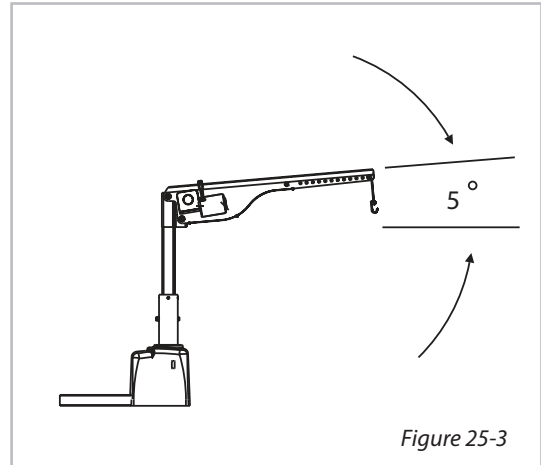

ADJUSTMENTS : ROTATION & MECHANICAL STOP

The amount of allowable rotation is determined by the Limit Rings indicated below. Loosen set screw of the Limit Rings with the 5/64 Allen Wrench so the Limit Rings move free and rotate away from the Limit Switches.

If installing the lift on the driver side, or if the post rotates in the wrong direction, simply reverse the wires at the rotational motor. [Figure 26-1]

Rotation Limit Switches may also need to be flipped to properly stop the motor. [Figure 26-1]

Set the Limit Ring and adjust the Bolt for the Mechanical Stop. The location of the Mechanical Stop is indicated by a small punch mark or hole located above one of the 3/8 holes. The Mechanical Stop is located on the Rotational Tube within the Motor Housing Assembly, [Figure 26-2] Power the

Motor Housing and rotate until the Rotational Tube makes contact with the Bolt, [Figure 26-3] [passenger side is clockwise (CW) & driver side is counter clockwise (CCW)]. Back the Bolt away and set the Limit Ring to the desired location in the "IN" position and tighten the set screw, [Figure 26-4].

Set the Mechanical Stop Bolt. Run the lift out and back in until the Limit Ring makes contact with the Limit Switch and stops. If the Post is in the desired location, screw the Bolt back in until it makes contact with the Stop, back it away 1/4 turn, hold the Bolt head, and tighten the Hex Nut (25 ft.lbs) against the Motor



CAUTION! Do not set the limits to over rotate the arm. Damage may occur to the vehicle.

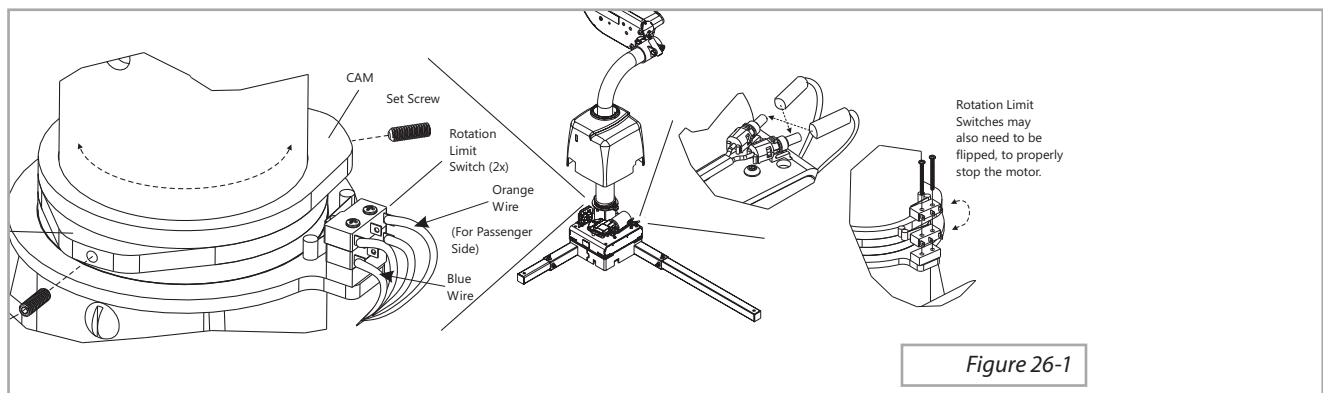

Figure 26-1

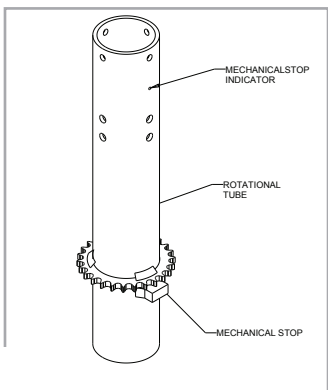

Figure 26-2

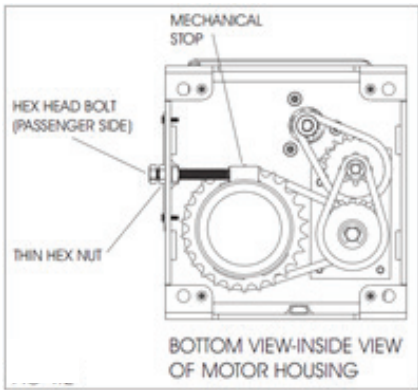

Figure 26-3

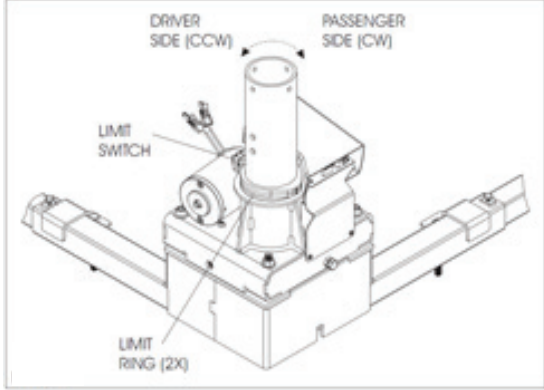

Figure 26-4

Housing, [Figure 27-1]. The Bolt should not make contact with the Stop when the Limit Ring engages the Limit Switch, [Figure 27-2].

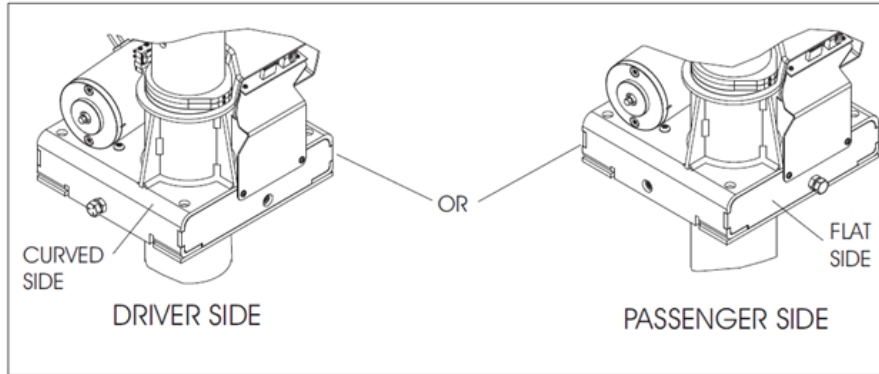

Figure 27-1

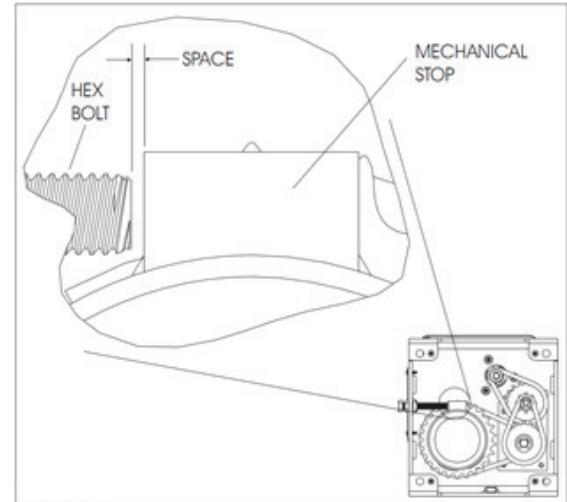

Figure 27-2

AL215

The AL215 is manufactured with manual rotation. The base has two set screws which act as mechanical stops to limit the rotation of the arm. [Figure 27-3].

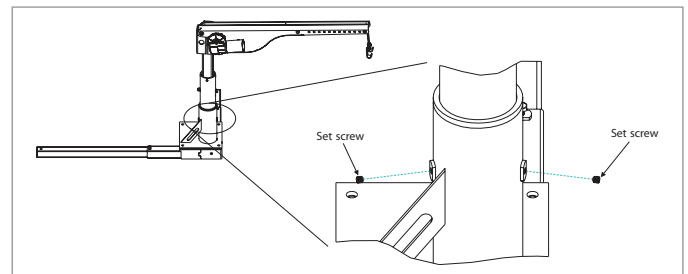

Figure 27-3

When the arm is rotated, it should stop at its full in and out positions. [Figure 27-4].

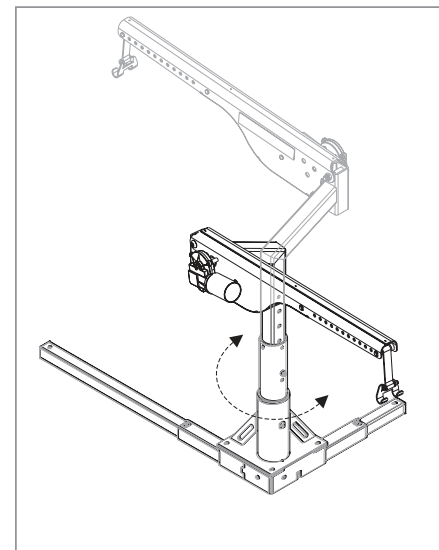

Figure 27-4



Be sure that the set screws are in place, but not so tight as to prohibit the arm from rotation.

DOCKING DEVICES

The Docking Device is an interface between the lift and the power chair or scooter.

Most power chairs and scooters can be lifted either by the center seat post or the four-post seat frame.

Types of Docking Devices

[Figures 28-1 and 28-2]

These Docking Devices are two of the most common and can lift most power chairs and scooters. However, many other devices are also available which may be more appropriate to your application.

Please consult the instructions provided with your Docking Device or contact our technical service department to find the specific device that will work best for you.

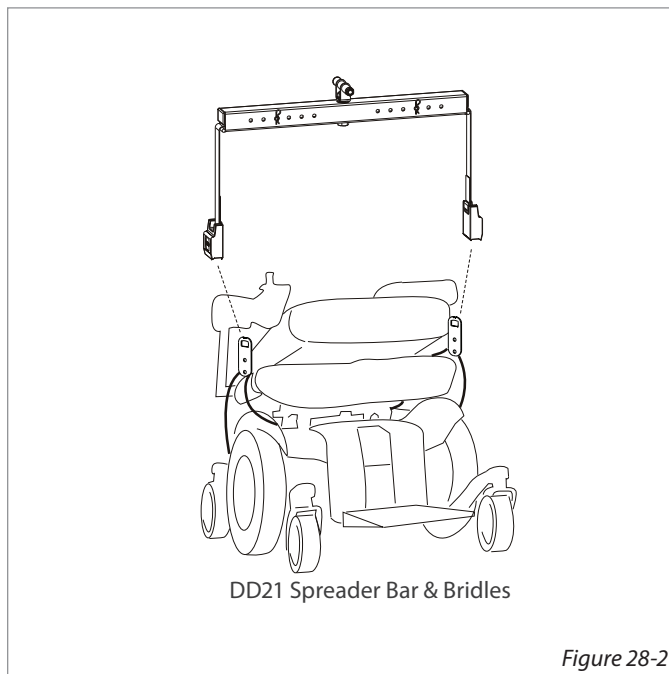
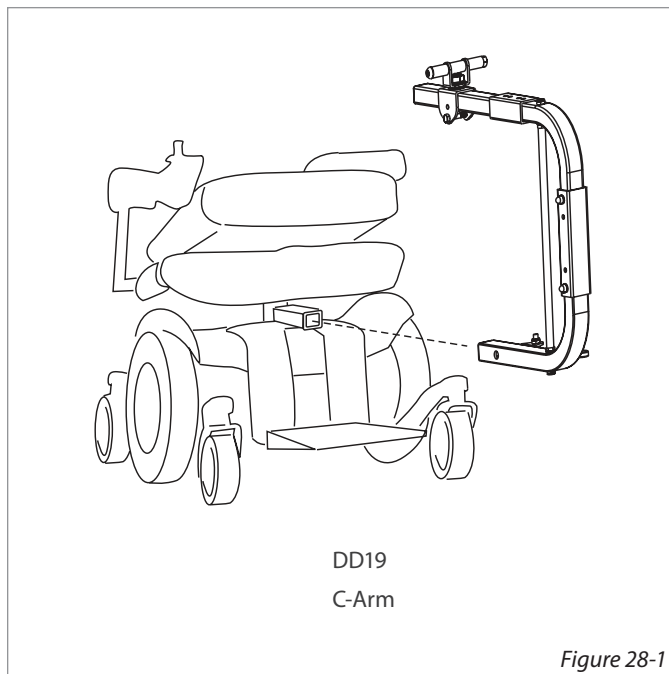

TROUBLESHOOTING

The following procedures are reserved for the approved installer/dealer. They should not be attempted by anyone without proper knowledge of automotive electrical circuitry.

Problem

Lift does not operate or lift operates slowly or intermittently.

Cause

Bad electrical connection(s) / Circuit breaker

Solutions

- Check / clean all connections that might be loose or dirty. The lift's motor requires quality electrical connections to operate at full capacity; any break in the wiring will slow down the motor and it will deteriorate prematurely.
- Inspect the full length of the wiring harness to ensure the insulation is not torn. The lift's vehicle power harness running through or under the vehicle is subject to road debris and rubbing against the vehicle's frame which can cause a short.
- Verify the circuit breaker. The circuit breaker is located about 6" from the connections to the vehicle's battery. The breaker will self-reset if overloaded; however, verify (with Ohm meter or test light) that the breaker is functioning. Or replace it with a new/known-good circuit breaker and perform the tests shown in [Figure 29-1].

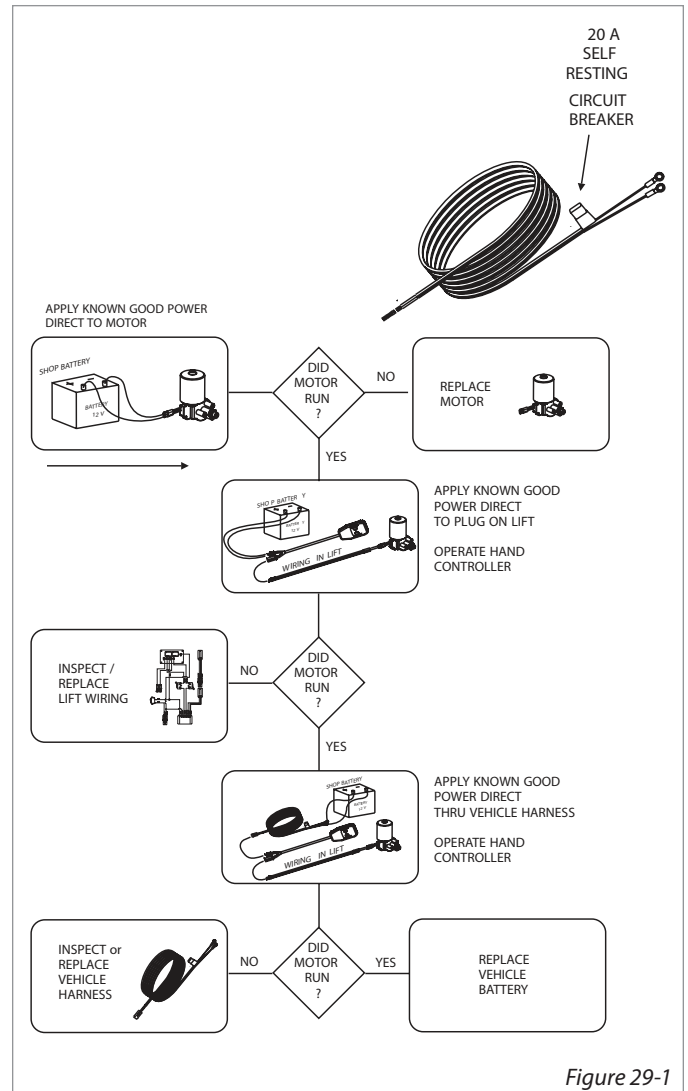

Problem

Lifting strap operates in reverse

Cause

Button was held too long and unwound the lifting strap like a yo-yo. The lifting strap wound in reverse.

Solutions

Press the button that extends the strap and continue to hold until the strap returns to the proper direction. Strap should always wrap over the top of the spool. [Figure 29-2]

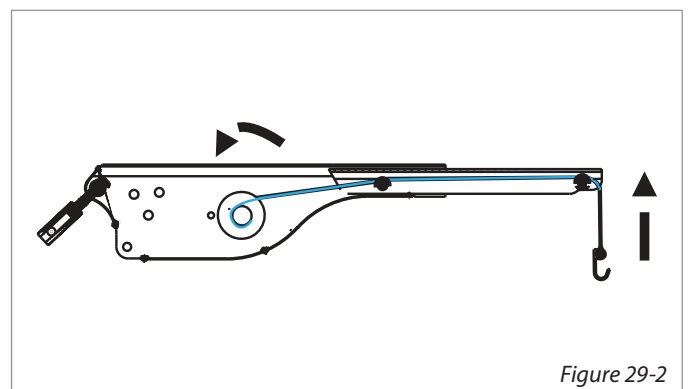

INSTALLER TROUBLE SHOOTING

NOTE: Be cautious when troubleshooting with a test light or voltage meter. You may get a false indication as shown below. It will indicate that a wire connection exists – but it may not necessarily be enough.

We strongly recommend that you examine both voltage and current, or isolate sections of the lift wiring using the process of elimination with a known good/fully charged 12V automotive battery or known good/fully charged power chair/scooter battery.

Problem

Scooter or chair tips front or back while being lifted.

Cause

Chair or Scooter is being lifted off center.

Solution

Adjust for center of gravity on docking device. Check to see if proper docking device is being used.

Problem

Lifting arm is hard to rotate.

Cause

Dry / dirty bushings.

Solution

Clean and lubricate bushings in base with white lithium grease or equivalent.

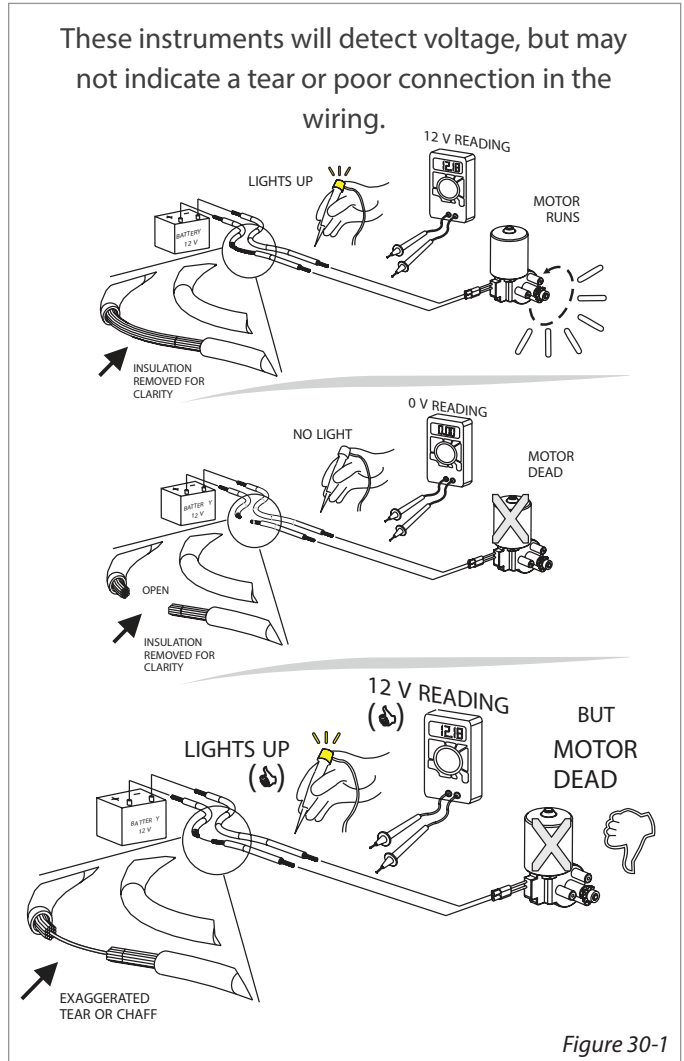

CAUTION!

Be careful when troubleshooting with a test light or voltage meter. They may give false indications.



AUTOMOTIVE TEST LIGHT

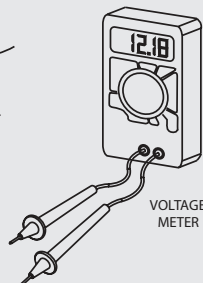

VOLTAGE METER

AL215

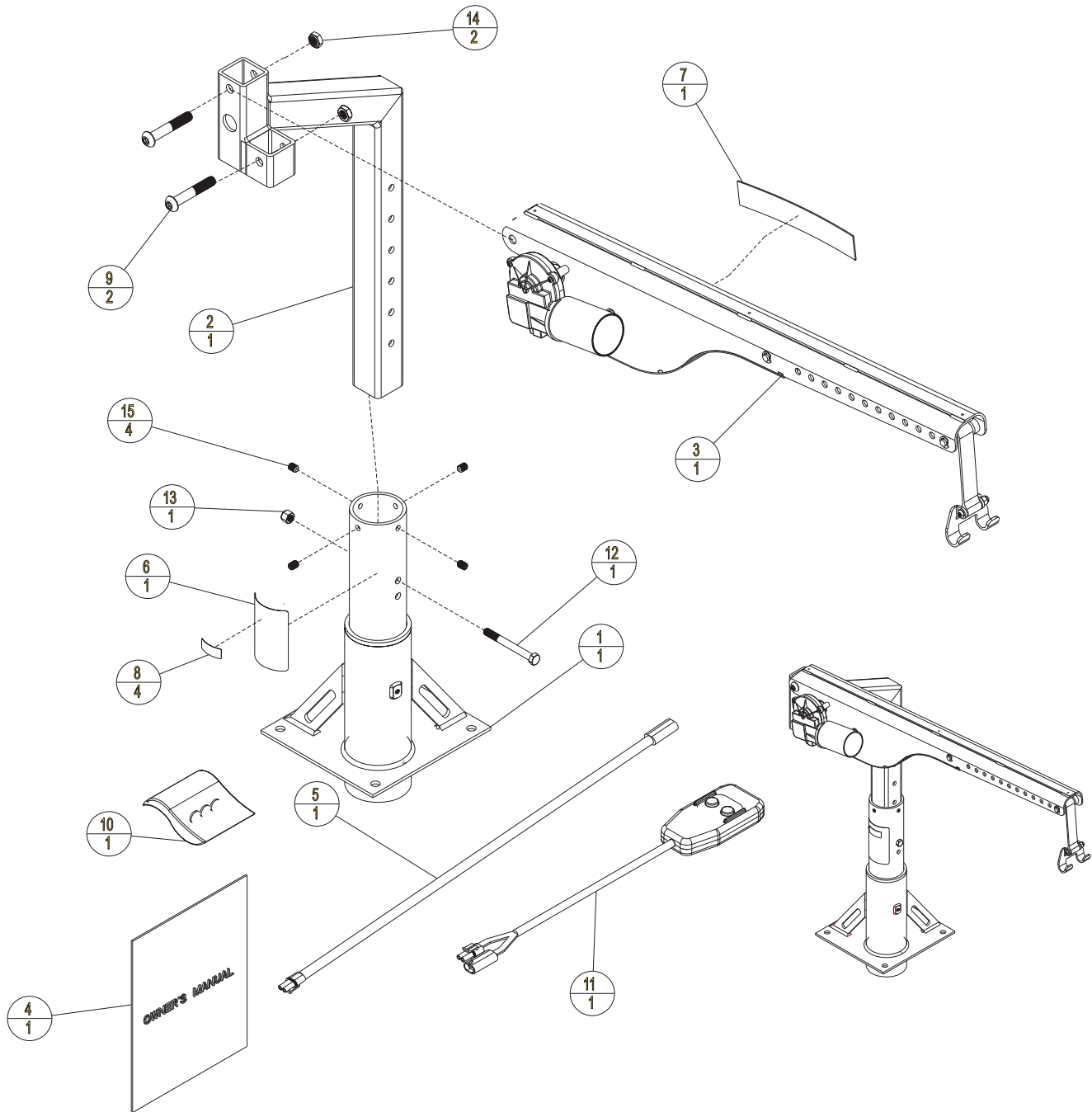

1. REFER TO 'AL215 & AL225 ARM' EXPLODED VIEW DRAWING FOR SUB-COMPONENTS OF 260-ZB01-AE

ASSEMBLY PARTS				ASSEMBLY PARTS			
ITEM	QTY	PART NO.	DESCRIPTION	ITEM	QTY	PART NO.	DESCRIPTION
1	1	200-3B01-AA	BASE COVER ASSEMBLY	9	2	BHCS-0_50-13-3_00-SS	BUTTON HEAD, 1/2-13 X 3.00, SS
2	1	240-ZB01-CA	SQUARE POST	10	1	H10-2B01-AA	HARDWARE, KIT, MANUAL BASE MOUNTING
3	1	260-ZB01-AE	ARM ASSEMBLY	11	1	H20000	2 BUTTON HAND CONTROL
4	1	999-3B01-AB	OWNER'S MANUAL	12	1	HHCS-0_37-16-3_50-Z	HEX HEAD, 3/8-16 X 3.50, ZP
5	1	ALA06550	AL065 HARNESS	13	1	NUT-0_37-16-NYLOCK-Z	NYLOCK NUT, 3/8-16, ZP
6	1	ALA21094	STICKER, "CAUTION"	14	2	NUT-0_50-13-NYLOCK-Z	NYLOCK NUT, 1/2-13, ZP
7	1	ALA21095	STICKER	15	4	SSCP-0_37-16-0_50-Z	SET SCREW 3/8-16 X 0.50, ZP
8	4	ALA99995	LABEL, SERIAL NUMBER				

INSTALLER EXPLODED VIEWS

AL225

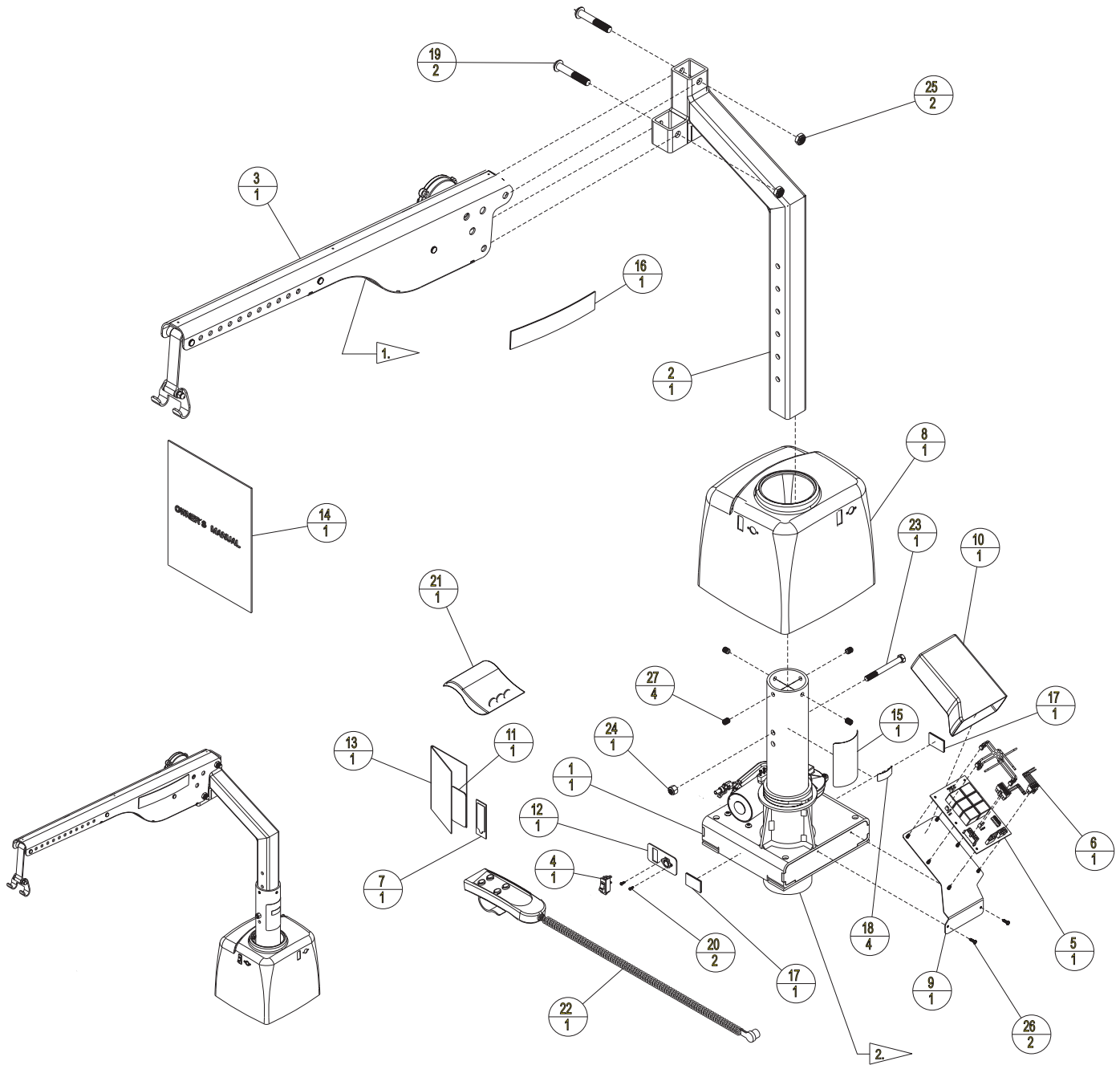

1. REFER TO "AL215 & AL225 ARM" EXPLODED VIEW DRAWING FOR SUB-COMPONENTS OF 260-ZB01-AE

2. REFER TO "AL225, AL425, & AL435 SERIES BASE" EXPLODED VIEW DRAWING FOR SUB-COMPONENTS OF 200-3B03-AA

ASSEMBLY PARTS				ASSEMBLY PARTS			
ITEM	QTY	PART NO.	DESCRIPTION	ITEM	QTY	PART NO.	DESCRIPTION
1	1	200-3B03-AA	MOTOR HOUSING ASSEMBLY	15	1	ALA21094	STICKER, "CAUTION"
2	1	240-ZB01-CA	SQUARE POST	16	1	ALA21095	STICKER, HARMAR
3	1	260-ZB01-AE	ARM ASSEMBLY	17	2	ALA28060	VELCRO, 1" PC FROM 25 YD ROLL
4	1	312-ZC04-AA	SWITCH, ON/OFF RED AND BLACK	18	4	ALA98995	LABEL, SERIAL NUMBER
5	1	390-00010	UNIVERSAL MOBILITY BOARD	19	2	BHCS-0_50-13-3_00-SS	BUTTON HEAD, 1/2-13 X 3.00, SS
6	1	390-00033	WIRE HARNESS, AL425 FOR UMB	20	2	BHCS-4-40-0_31-SS	BUTTON HEAD 4-40 X 0.3125
7	1	390-00074	GREASE, ELECTRICAL SILICON, GEL-207, 2 GRAM PACK	21	1	H10-2B03-AA	HARDWARE, KIT, POWER BASE MOUNTING
8	1	410-3B03-AA	BASE COVER	22	1	H41000	HAND CONTROL-4 BUTTON
9	1	515-2B04-CA	PCB MOUNTING PLATE FOR UMB	23	1	HHCS-0_37-16-3_50-Z	HEX HEAD, 3/8-16 X 3.50, ZP
10	1	520-00001	CIRCUIT BOARD SLEEVE	24	1	NUT-0_37-16-ANYLOCK-Z	NYLOCK NUT, 3/8-16, ZP
11	1	520-00030	LABEL, BLACK, BASE HOLE COVER	25	2	NUT-0_50-13-ANYLOCK-Z	NYLOCK NUT, 1/2-13, ZP
12	1	530-00333C	BACKING PLATE, AL425 CONTROL, POWDER COATED	26	2	PHMS-6-32-0_50-Z	PAN HEAD, # 6-32 X 0.50, ZP
13	1	630-00000	INSTRUCTION, BLACK LABEL	27	4	SSCP-0_37-16-0_50-Z	SET SCREW 3/8-16 X 0.50, ZP
14	1	999-3B01-AB	OWNER'S MANUAL				

AL425

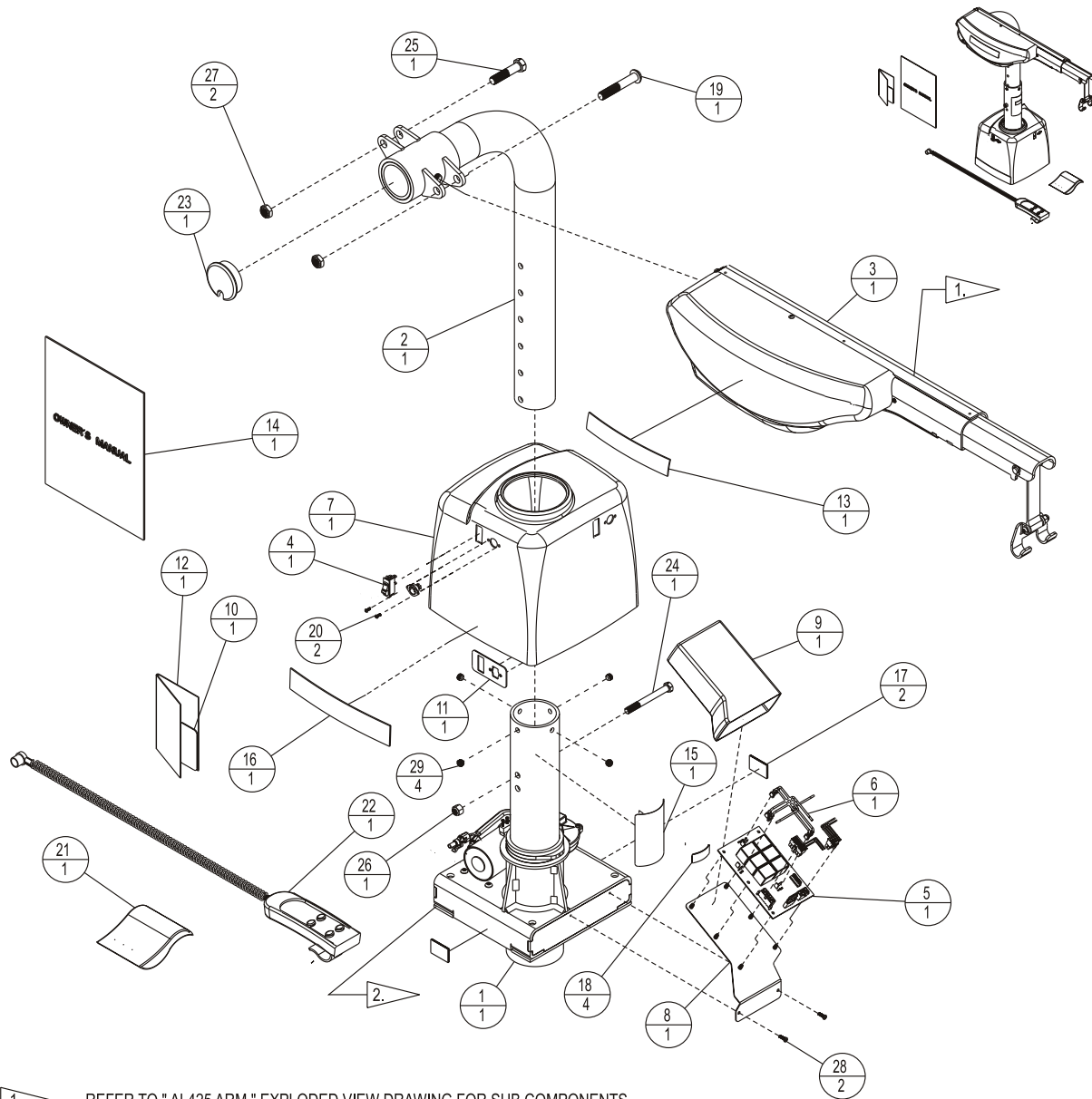

1. REFER TO "AL425 ARM" EXPLODED VIEW DRAWING FOR SUB COMPONENTS

2. REFER TO "BASE" EXPLODED VIEW DRAWING FOR SUB COMPONENTS

ASSEMBLY PARTS				ASSEMBLY PARTS			
ITEM	QTY	PART NO.	DESCRIPTION	ITEM	QTY	PART NO.	DESCRIPTION
1	1	200-3B03-AA	MOTOR HOUSING ASSEMBLY	16	1	ALA21095	STICKER, HARMAR
2	1	240-ZB03-AC	COLLAR & POST ASSEMBLY	17	2	ALA28 060	VELCRO, 1" PC from 25 YD ROLL
3	1	260-3B03-AA	HOISTASSEMBLY	18	4	ALA99 995	LABEL, SERIAL NUMBER
4	1	312-ZC04-AA	SWITCH, ON/OFF RED ANDBLACK	19	1	BHCS-0_50-13-3_00-SS	BUTTON HEAD, 1/2-13 X 3.00, SS
5	1	360-00010	UNIVERSAL MOBILITY BOARD	20	2	BHCS-4-40-0_31-SS	BUTTON HEAD 4-40 x 0.3125
6	1	390-00033	WIRE HARNESS, AL425 FOR UMB	21	1	H10-2B03-AA	HARDWARE, KIT, POWER BASE MOUNTING
7	1	410-3B03-AA	BASECOVER	22	1	H41000	HAND CONTROL- 4 BUTTON
8	1	515-2B04-CA	PCB MOUNTING PLATE FOR UMB	23	1	H425009	ROUND TUBE PLUG
9	1	520-00001	CIRCUIT BOARD SLEEVE	24	1	HHCS-0_37-16-3_50-Z	HEX HEAD, 3/8-16 X 3.50, ZP
10	1	520-00030	LABEL, BLACK, BASE HOLE COVER	25	1	HHCS-0_50-13-2_25-Z	HEX HEAD, 1/2-13 X 2.25, ZP
11	1	530-00333C	BACKING PLATE, AL425 CONTROL, POWDERCOATED	26	1	NUT-0_37-16-NYLOCK-Z	NYLOCK NUT, 3/8-16, ZP
12	1	630-00060	INSTRUCTION, BLACK LABEL	27	2	NUT-0_50-13-NYLOCK-Z	NYLOCK NUT, 1/2-13, ZP
13	1	910-3L02-AA	STICKER	28	2	PHMS-6-32-0_50-Z	PAN HEAD, # 6-32 X 0.50, ZP
14	1	999-3B01-AB	OWNER'S MANUAL	29	4	SSCP-0_375-0_3	SET SCREW, 3/8-16 x 5/16"L ZINC
15	1	ALA21094	STICKER, "CAUTION"				

INSTALLER EXPLODED VIEWS

AL425HD

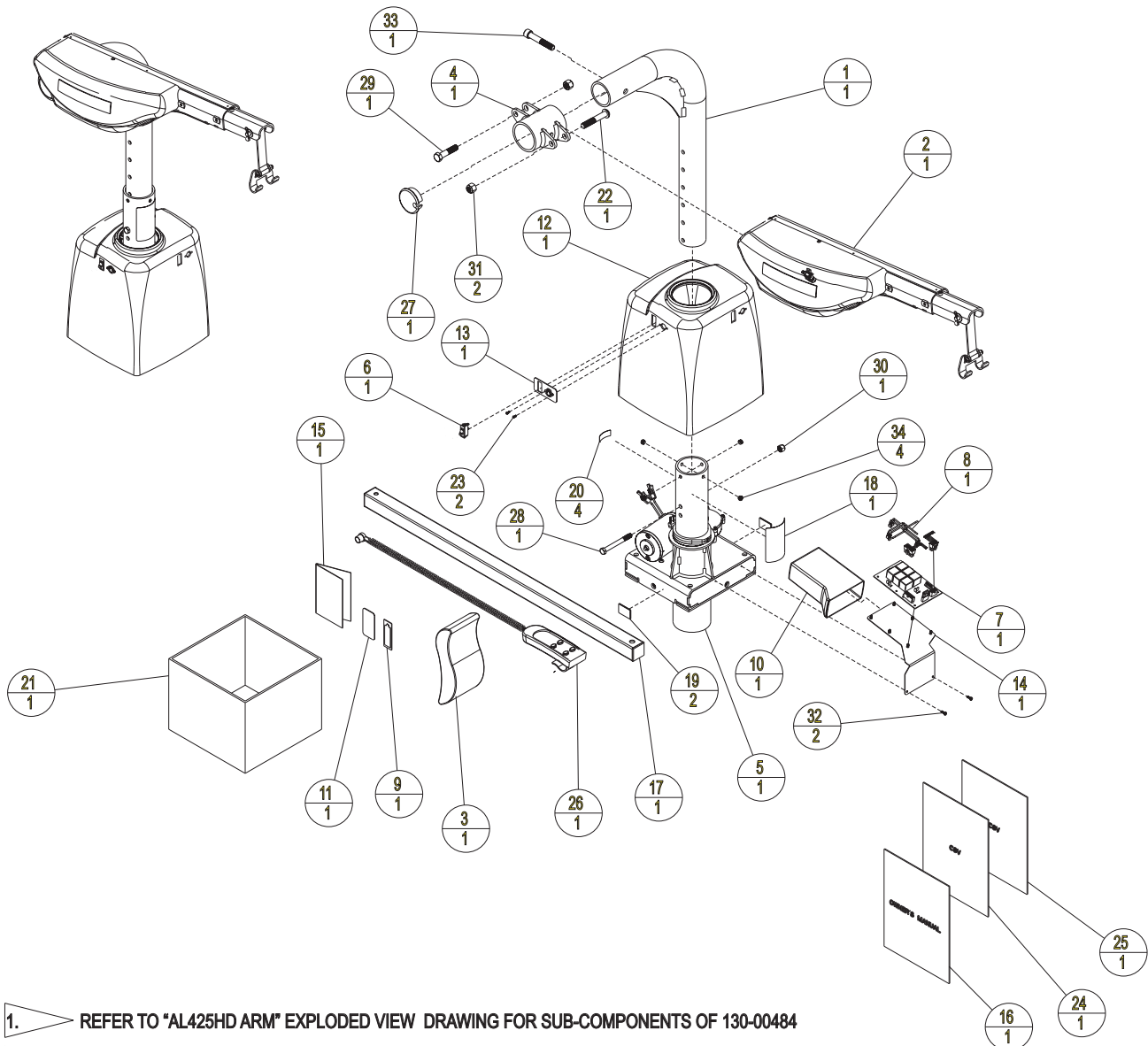

1. REFER TO "AL425HD ARM" EXPLODED VIEW DRAWING FOR SUB-COMPONENTS OF 130-00484

2. REFER TO "AL425HD BASE" EXPLODED VIEW DRAWING FOR SUB-COMPONENTS OF 275-3D05-AA

ASSEMBLY PARTS				ASSEMBLY PARTS			
ITEM	QTY	PART NO.	DESCRIPTION	ITEM	QTY	PART NO.	DESCRIPTION
1	1	120-00249C	PC AL425HD OFFSET POST	18	1	ALA21084	STICKER, "CAUTION"
2	1	130-00484	HD HOIST ASSEMBLY	19	2	ALA28060	VELCRO, 1" PC from 25 YD ROLL
3	1	140-00088	MOUNTING KIT; TALL BA	20	4	ALA99995	LABEL, SERIAL NUMBER
4	1	245-ZB03-CC	PC COLLAR	21	1	BA22	HD BASE ADAPTER
5	1	275-3D05-AA	POWER ROTATION ASSEMBLY, TRUCK LIFT	22	1	BHCS-0_50-13-3_00-SS	BUTTON HEAD, 1/2-13 X 3.00, SS
6	1	312-ZC04-AA	SWITCH, ON/OFF RED AND BLACK	23	2	BHCS-4-40-0_31-SS	BUTTON HEAD 4-40 x 0.3125
7	1	360-00010	UNIVERSAL MOBILITY BOARD	24	1	CSV-000034	FLAT FLOOR INSTALLATION SHEET
8	1	390-00033	WIRE HARNESS, AL425 FOR UMB	25	1	CSV-000035	MECHANICAL STOP INSTRUCTION SHEET
9	1	390-00074	GREASE, ELECTRICAL SILICON, GEL-207	26	1	H41000	HAND CONTROL- 4 BUTTON
10	1	520-00001	CIRCUIT BOARD SLEEVE	27	1	H420009	ROUND TUBE PLUG
11	1	520-00030	LABEL, BLACK, BASE HOLE COVER	28	1	HHCS-0_37-16-3_50-Z	HEX HEAD, 3/8-16 X 3.50, ZP
12	1	520-00033	TALL BASE COVER	29	1	HHCS-0_50-13-2_25-Z	HEX HEAD, 1/2-13 X 2.25, ZP
13	1	530-00333	PC BACKING PLATE, AL425 CONTROL	30	1	NUT-0_37-16-NYLOCK-Z	NYLOCK NUT, 3/8-16, ZP
14	1	530-00380C	PC PCB BRACKET WITH STANDOFFS	31	2	NUT-0_50-13-NYLOCK-Z	NUT, NYLOCK, 1/2-13, ZP
15	1	630-00060	INSTRUCTION, BLACK LABEL	32	2	PHMS-6-32-0_50-Z	PAN HEAD, # 6-32 X 3.00, ZP
16	1	899-3801-AB	OWNER'S MANUAL	33	1	SHCS-0_50-13-3_00-Z	SOCKET HEAD, 1/2-13 X 3.00, ZP
17	1	AL207	LONG LEG EXTENSION	34	4	SSCP-0_375-0_312-Z	SET SCREW, 3/8-16 x 5/16"L, ZINC

AL435

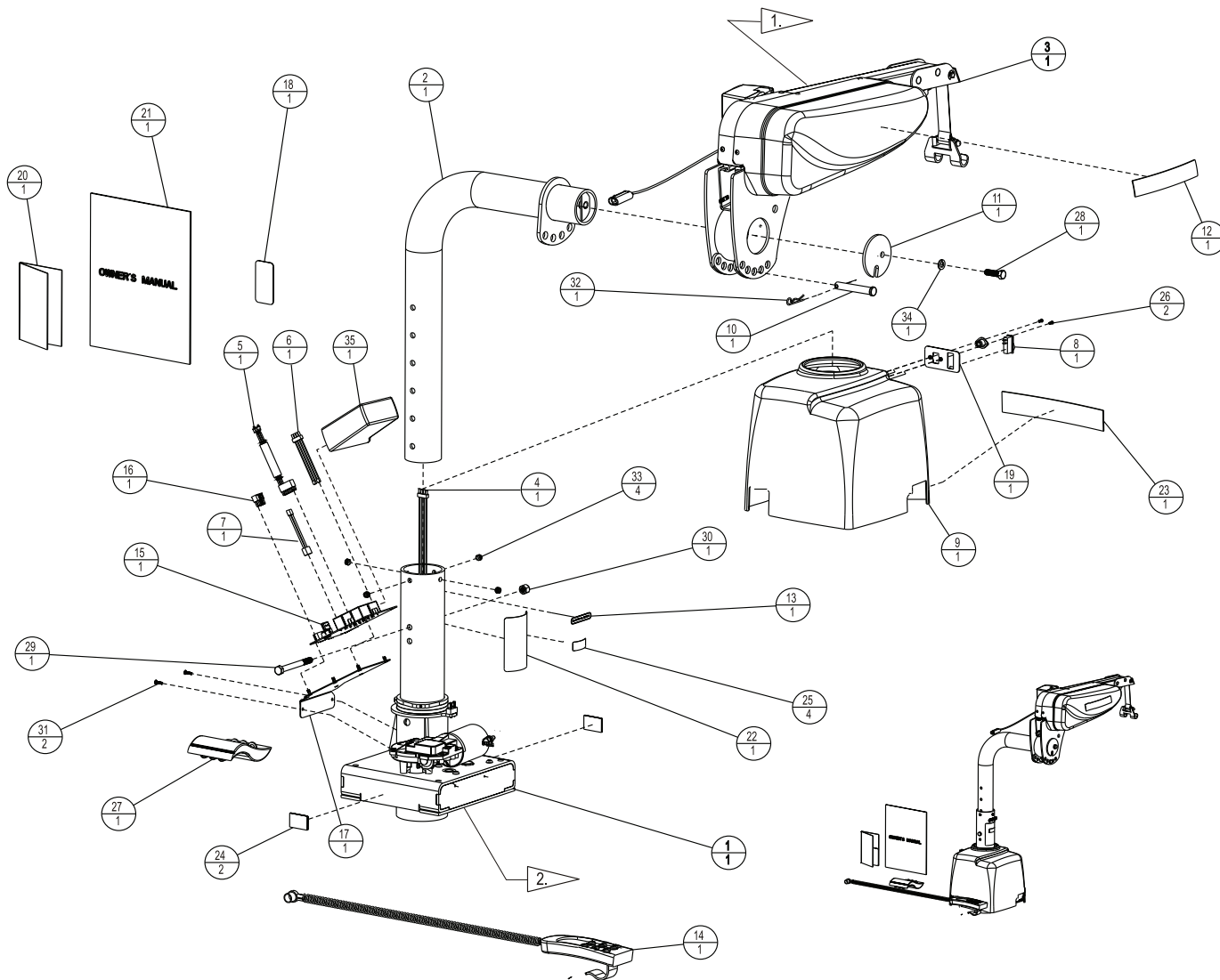

1. REFER TO "AL435 ARM" EXPLODED VIEW DRAWING FOR SUB COMPONENTS

2. REFER TO "BASE" EXPLODED VIEW DRAWING FOR SUB COMPONENTS

ITEM	QTY	PART NO.	ASSEMBLY PARTS	DESCRIPTION
1	1	200-3B03-AA		MOTOR HOUSING ASSEMBLY
2	1	250-ZB09-CE		AL435 STANDARD COLUMN ARM WELDMENT
3	1	275-ZB09-AD		3 AXIS LIFTING ARM
4	1	303-ZB09-AE		HARNES, UPPER COLUMN
5	1	306-ZB04-AB		HARNES, LIMIT SWITCHES, AL435
6	1	306-ZB09-AF		LOWER COLUMN EQ HARNES
7	1	307-ZB09-AD		EQ ROTATIONAL MOTOR HARNES
8	1	312-ZC04-AA		SWITCH, ON/OFF RED AND BLACK
9	1	410-3B03-AA		BASE COVER
10	1	450-00001-01		CLEVIS PIN, 1/2" x 3.00", GRADE 8, ZP
11	1	569-ZB09-CA		LIFT ARM RETAINER
12	1	910-3L02-AA		STICKER
13	1	916-ZB09-AA		PATENT STICKER
14	1	H61000		HAND CONTROL- 6 BUTTON
15	1	360-00010		UNIVERSAL MOBILITY BOARD
16	1	380-00074		POWER AND CONTROL HARNES, UMB, 3AXIS AL435 BOOM LIFT
17	1	515-ZB04-CA		PCB MOUNTING PLATE FOR UMB

ITEM	QTY	PART NO.	ASSEMBLY PARTS	DESCRIPTION
18	1	520-00030		LABEL, BLACK, BASE HOLE COVER
19	1	530-00333C		BACKING PLATE, CONTROL, POWDER COATED
20	1	630-00060		INSTRUCTION, BLACK LABEL
21	1	999-3B01-AB		OWNER'S MANUAL
22	1	ALA21094		STICKER, "CAUTION"
23	1	ALA21095		STICKER
24	2	ALA28060		VELCRO, 1" PC FROM 25 YD ROLL
25	4	ALA99995		LABEL, SERIAL NUMBER
26	2	BHCS-4-40-0_31-SS		BUTTON HEAD 4-40 x 0.3125
27	1	H10-ZB03-AA		HARDWARE, KIT, POWER BASE MOUNTING
28	1	HHCS-0_37-16-1_25-Z		HEX HEAD, 3/8-16 X 1.25, ZP
29	1	HHCS-0_37-16-3_50-Z		HEX HEAD, 3/8-16 X 3.50, ZP
30	1	NUT-0_37-16-NYLOCK-Z		NYLOCK NUT, 3/8-16, ZP
31	2	PHMS-6-32-0_50-Z		PAN HEAD, # 6-32 X 0.50, ZP
32	1	PIN-0_09-0_37-1_62-HP-SS		HAIR PIN, 1.62 L FOR 1/4-1/2 PIN
33	4	SSCP-0_375-0_312-Z		SET SCREW, 3/8-16 x 5/16", ZINC
34	1	WASH-0_37-0_68-0_09-SL-Z		SPRING LOCK WASHER, 3/8, ZP
35	1	520-0001		CIRCUIT BOARD SLEEVE

INSTALLER EXPLODED VIEWS

AL435 T

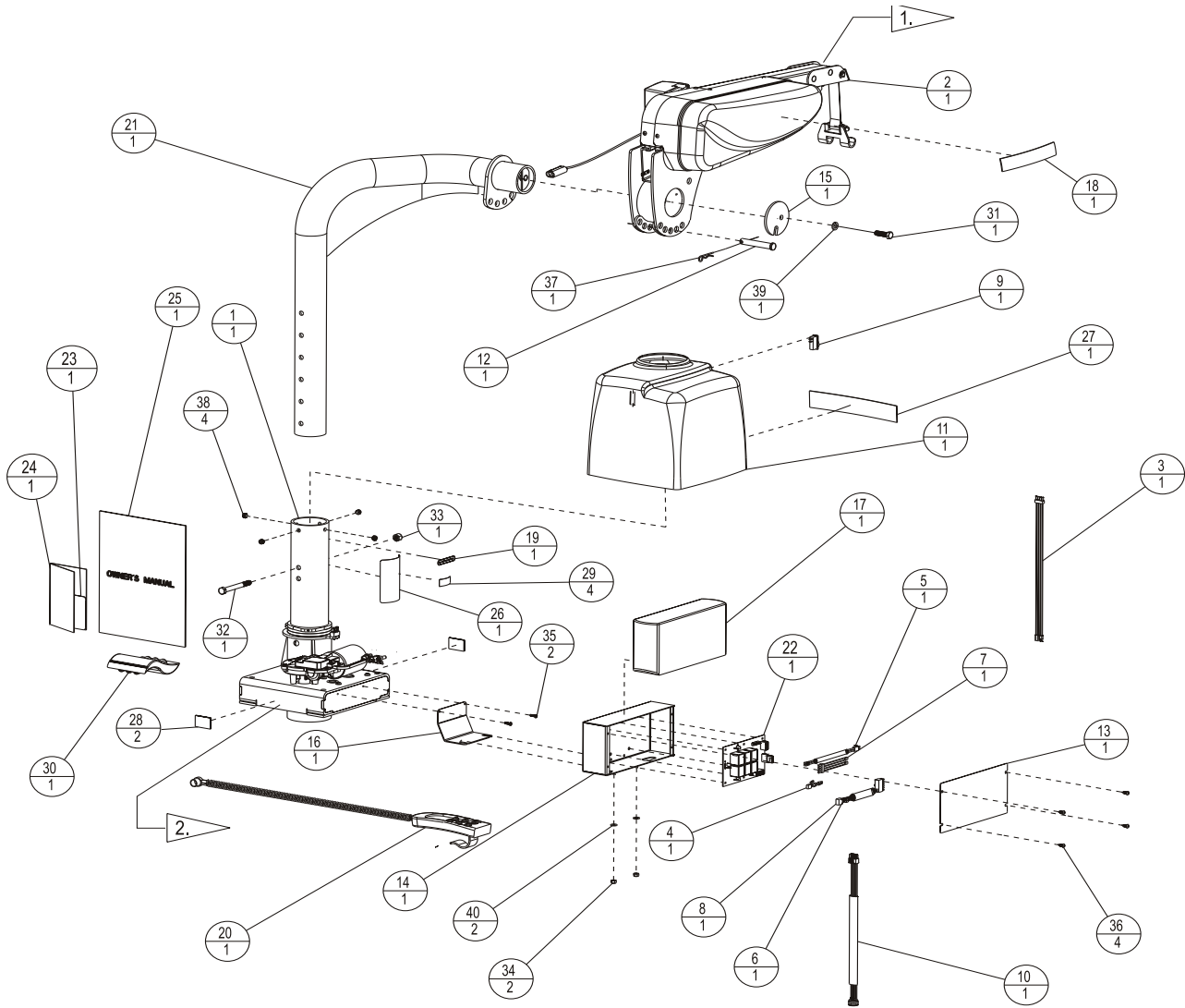

1. FOR MOTOR HOUSING ASSEMBLY COMPONENTS SEE 200-3B03-AA PRINT.

2. FOR 3 AXIS LIFTING ARM COMPONENTS SEE 275-ZB09-AB PRINT.

ASSEMBLY PARTS				ASSEMBLY PARTS			
ITEM	QTY	PART NO.	DESCRIPTION	ITEM	QTY	PART NO.	DESCRIPTION
1	1	200-3B03-AA	MOTOR HOUSING ASSEMBLY	21	1	250-ZB15-CC	AL435T POST ASSEMBLY
2	1	275-ZB09-AD	3 AXIS LIFTING ARM	22	1	360-00010	UNIVERSAL MOBILITY BOARD
3	1	303-ZB09-AE	HARNESS, UPPER COLUMN	23	1	520-00030	LABEL, BLACK, BASE HOLE COVER
4	1	304-ZB09-AE	MAIN POWER HARNESS	24	1	630-00060	INSTRUCTION, BLACK LABEL
5	1	305-ZB04-AB	HARNESS, POWER, AL435	25	1	999-3B01-AB	OWNER'S MANUAL
6	1	306-ZB04-AB	HARNESS, LIMIT SWITCHES, AL435	26	1	ALA21094	STICKER, "CAUTION"
7	1	306-ZB09-AF	LOWER COLUMN EQ HARNESS	27	1	ALA21095	STICKER
8	1	307-ZB09-AD	EQ ROTATIONAL MOTOR HARNESS	28	2	ALA28060	VELCRO, 1" PC FROM 25 YD ROLL
9	1	312-ZC04-AA	SWITCH, ON/OFF RED AND BLACK	29	4	AL49995	LABEL, SERIAL NUMBER
10	1	363-3B04-AA	HARNESS, CONTROL, 6 CHANNEL, 7 PIN DIN	30	1	H10-2B03-AA	HARDWARE, KIT, POWER BASE MOUNTING
11	1	410-1D05-AB	BASE COVER, AL835	31	1	HHCS-0_37-16-1_25-Z	HEX HEAD, 3/8-16 X 1.25, ZP
12	1	450-00001-01	CLEVIS PIN, 1/2" X 3.00", GRADE 8, ZP	32	1	HHCS-0_37-16-3_50-Z	HEX HEAD, 3/8-16 X 3.50, ZP
13	1	538-ZB09-CB	CONTROL BOX COVER	33	1	NUT-0_37-16-NYLOCK-Z	NYLOCK NUT, 3/8-16, ZP
14	1	539-ZB09-CC	CONTROL BOX	34	2	NUT-10-24-NYLOCK-Z	NUT, NYLOCK, 10-24, ZP
15	1	569-ZB09-CA	LIFT ARM RETAINER	35	2	PHMS-4-32-0_50-Z	PAN HEAD, # 6-32 X 0.50, ZP
16	1	571-3B09-CA	RELAY BOX BRACKET	36	4	PHSS-4-1_50-Z	PAN HEAD, PHILLIPS, NO. 8 X 0.50, ZP
17	1	906-ZB09-AA	RELAY BOX COVER	37	1	PIN-0_09-0_37-1_62-HP-SS	HAIR PIN, 1.52 L FOR 14-12 PIN
18	1	910-3L02-AA	STICKER	38	4	SSCP-0_375-0_312-Z	SET SCREW, 3/8-16 X 5/16", ZINC
19	1	916-ZB09-AA	PATENT STICKER	39	1	WASH-0_37-0_68-0_08-SL-Z	SPRING LOCK WASHER, 3/8, ZP
20	1	HB1000	HAND CONTROL- 6 BUTTON	40	2	WASH-10-0_5-0_05-RH-Z	WASHER, 3/8" ID X 5/8" OD X 0.06" THICK, 18-8SS

AL215 & AL225 ARM

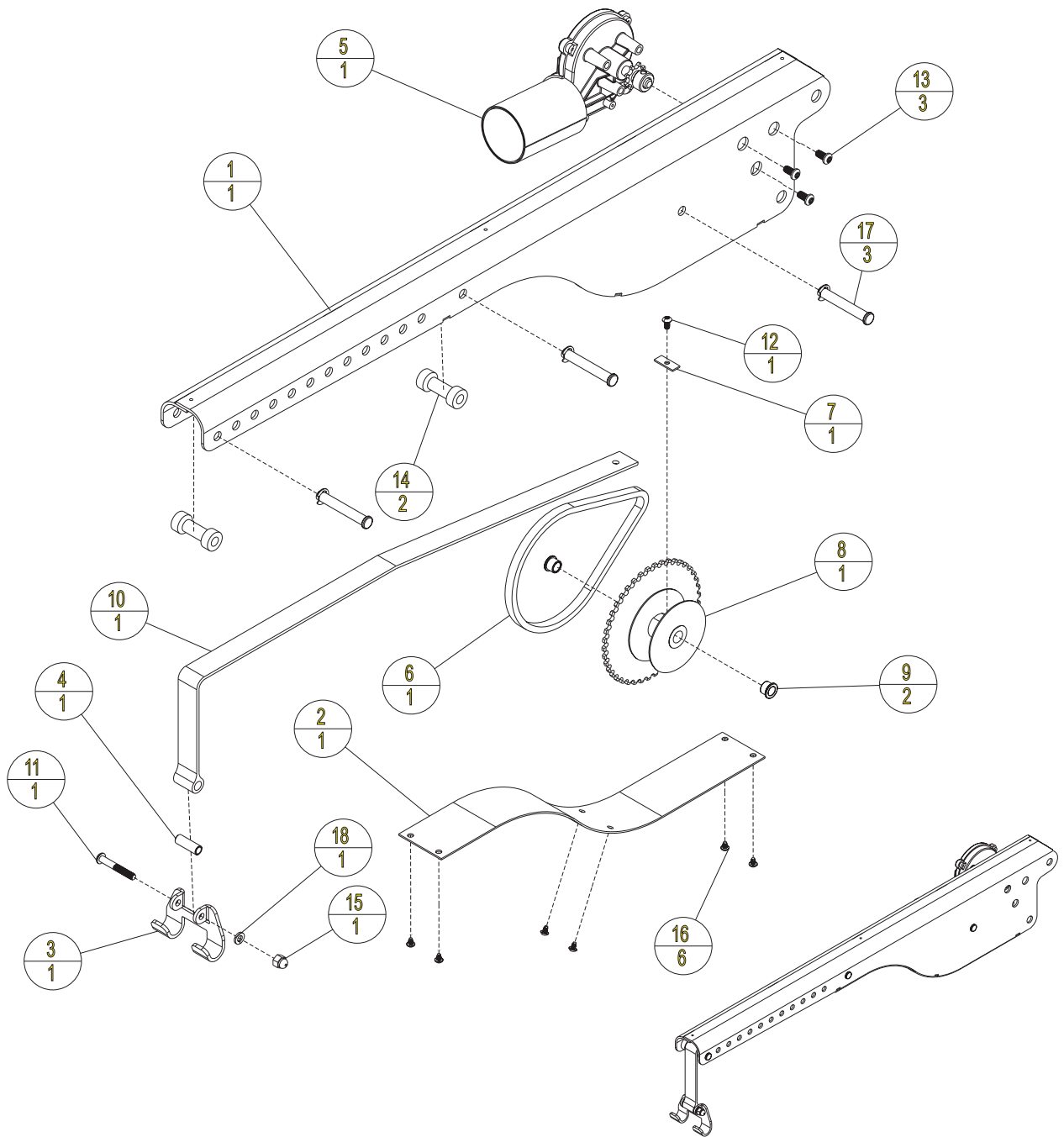

ASSEMBLY PARTS				ASSEMBLY PARTS			
ITEM	QTY	PART NO.	DESCRIPTION	ITEM	QTY	PART NO.	DESCRIPTION
1	1	281-ZB01-CD	HOIST HOUSING	10	1	ALA67997	LIFTING STRAP
2	1	570-ZB01-CB	PC HOIST HOUSING COVER	11	1	BHCS-0_25-20-1_75-SS	BUTTON HEAD, 1/4-20 x 1.75, SS
3	1	590-ZB01-CA	PC DETACHABLE HOOK	12	1	BHCS-10-32-0_37-BO	BUTTON HEAD, 10-32 x 0.37, BO
4	1	591-ZB01-CA	HOOK SLEEVE	13	3	BHCS-M6-1_00-16-SS	BUTTON HEAD, M6-1 X 16MM, SS
5	1	700-ZB01-AA	SMALL LIFTING MOTOR	14	2	H225402	AL215 & AL225 ROLLER
6	1	ALA21020	SPOOL CHAIN, 50 LINKS	15	1	NUT-0_25-20-ACORN-N	ACORN NUT, 1/4-20, NI
7	1	ALA21055	STRAP TAB	16	6	PHTS-8-32-0_25-BZ	PAN HEAD - THREAD FORMING, 8-32 X 0.25, BZ
8	1	ALA214-PLT	SPOOL	17	3	PIN-0_37-2_50-CL-Z	CLEVIS PIN & E-CLIP: 3/8 X 2.50, ZP
9	2	ALA21410	FLANGE BUSHING BRZ 3/8X1/2X3/8	18	1	WASH-0_25-0_50-0_06-SL-Z	1/4" SPLIT LOCK WASHER

INSTALLER EXPLODED VIEWS

AL425 ARM

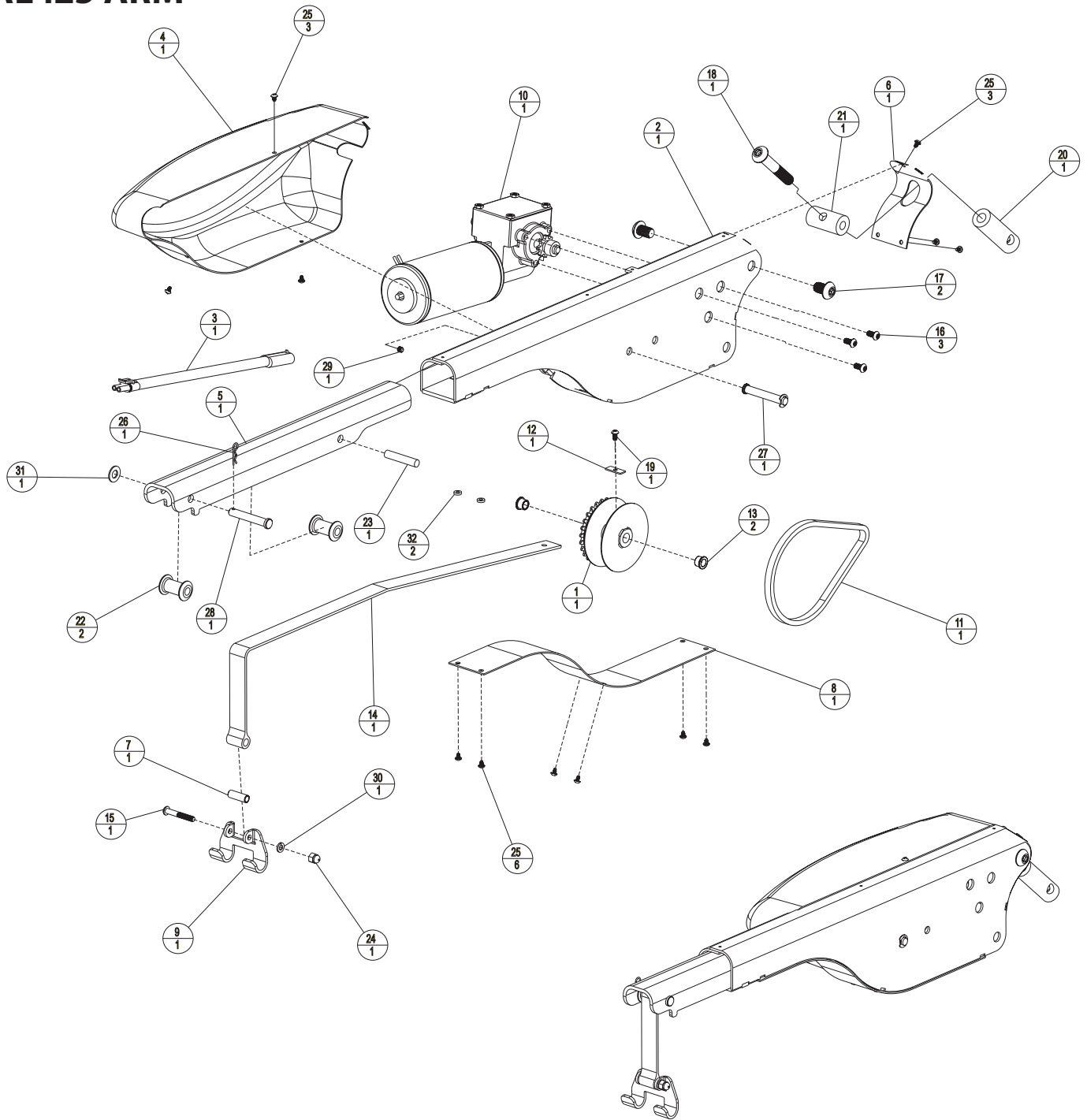

ASSEMBLY PARTS				ASSEMBLY PARTS			
ITEM	QTY	PART NO.	DESCRIPTION	ITEM	QTY	PART NO.	DESCRIPTION
1	1	214-3B03-PA	SPOOL, 28 TOOTH, AL-425 LIFTING	17	2	BHCS-0_50-13-0_75-SS	BUTTON HEAD, 1/2-13 X 0.75, SS
2	1	281-2B03-CB	HOIST HOUSING	18	1	BHCS-0_50-13-3_00-SS	BUTTON HEAD, 1/2-13 X 3.00, SS
3	1	311-2B09-AA	MALE TO FEMALE HARNESS	19	1	BHCS-10-32-0_37-BO	BUTTON HEAD, 10-32 X 0.37, BO
4	1	460-2B03-AA	HOIST MOTOR COVER	20	1	H425421-PLT	TURNBUCKLE NUT, PLATED
5	1	570-3B03-CA	HOIST INNER ARM	21	1	H425423-PLT	TURNBUCKLE X-CYLINDER
6	1	572-2B03-CB	HOIST HOUSING COVER - BACK	22	2	H425444	STRAP ROLLER
7	1	591-2B01-CA	HOOK SLEEVE	23	1	H425446	PIN, ROLLER, STRAP, AL425
8	1	570-2B01-CB	PC HOIST HOUSING COVER	24	1	NUT-0_25-20-ACORN-N	ACORN NUT, 1/4-20, NI
9	1	890-2B01-CA	PC DETACHABLE HOOK	25	12	PHTS-8-32-0_25-BZ	PIN HEAD - THREAD FORMING, 8-32 X 0.25, BZ
10	1	700-2B03-AA	MOTOR, LIFTING, EUCLID	26	1	PIN-0_25-0_31-CO-Z	HAIR COTTER PIN
11	1	ALJA21020	SPOOL CHAIN, 60 LINKS	27	1	PIN-0_37-2_50-CL-Z	CLEVIS PIN & E-CLIP: 3/8 X 2.50, ZP
12	1	ALJA21055	STRAP TAB	28	1	PIN-0_38-2_25-Z	3/8 X 2.25 CLEVIS PIN
13	2	ALJA21410	FLANGE BUSHING BRZ 3/8X1/2X3/8	29	1	SSCP-0_25-28-0_375	SET SCREW: 1/4-28 X 0.37
14	1	ALJA67997	LIFTING STRAP	30	1	WASH-0_25-0_06-SL-Z	1/4" SPLIT LOCK WASHER
15	1	BHCS-0_25-20-1_75-SS	BUTTON HEAD, 1/4-20 X 1.75, SS	31	1	WASH-0_375-RH-Z	3/8 WASHER
16	3	BHCS-0_25-28-0_50-SS	BUTTON HEAD 1/4-28 X 0.50	32	2	WASH-10-0_37-0_08-RH-R	WASHER, #10 X 0.37 X 0.08, NEOPRENE RUBBER

INSTALLER EXPLODED VIEWS

AL425HD ARM

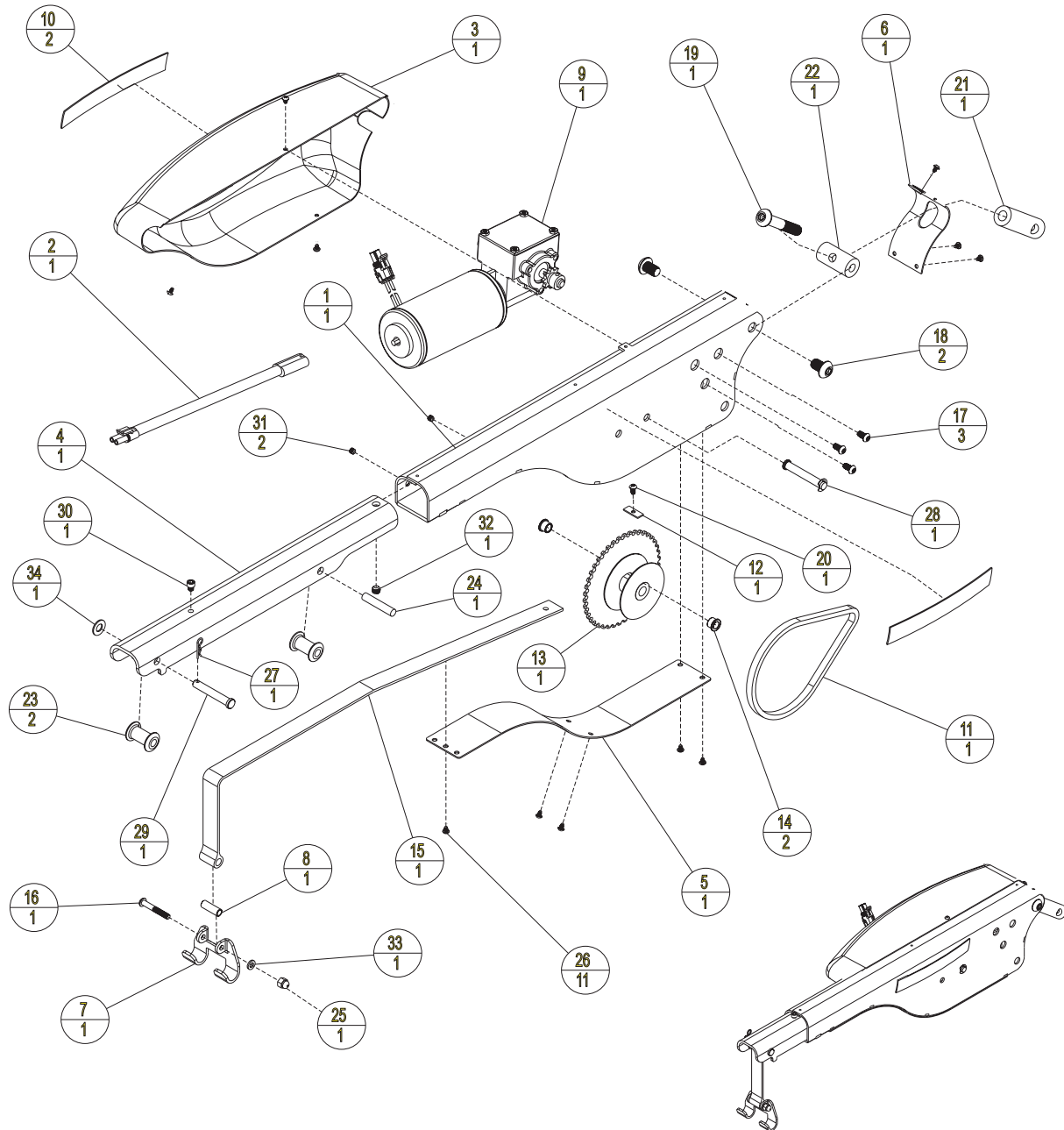

ASSEMBLY PARTS				ASSEMBLY PARTS			
ITEM	QTY	PART NO.	DESCRIPTION	ITEM	QTY	PART NO.	DESCRIPTION
1	1	261-ZB03-CB	PC HOIST HOUSING	18	2	BHCS-0_50-13-0_75-SS	BUTTON HEAD, 1/2-13 X 0.75, SS
2	1	311-ZB09-AA	MALE TO FEMALE HARNESS	19	1	BHCS-0_50-13-0_00-SS	BUTTON HEAD, 1/2-13 X 3.00, SS
3	1	490-ZB03-AA	HOIST MOTOR COVER	20	1	BHCS-10-32-0_37-BO	BUTTON HEAD, 10-32 X 0.37, BO
4	1	570-3B03-CA	PC HOIST INNER ARM	21	1	H425421-PLT	TURNBUCKLE NUT
5	1	570-ZB01-CB	PC HOIST HOUSING COVER	22	1	H425423-PLT	TURNBUCKLE X-CYLINDER
6	1	572-ZB03-CB	HOIST HOUSING COVER - BACK	23	2	H425444	STRAP ROLLER
7	1	590-ZB01-CA	PC DETACHABLE HOOK	24	1	H425445	PIN, ROLLER, STRAP, AL425
8	1	591-ZB01-CA	HOOK SLEEVE	25	1	NUT-0_25-20-ACORN-N	ACORN NUT, 1/4-20, NI
9	1	700-3C01-AA	HYBRID LIFTING MOTOR, EUCLID	26	11	PHTS-8-32-0_25-BZ	PAN HEAD - THREAD FORMING, 8-32 X 0.25, BZ
10	2	910-3L02-AA	STICKER	27	1	PIN-0_25-0_31-CO-Z	HAIR COTTER PIN
11	1	ALA21020	SPOOL CHAIN, 50 LINKS	28	1	PIN-0_37-2_50-CL-Z	CLEVIS PIN & E-CLIP: 3/8 X 2.50, ZP
12	1	ALA21055	STRAP TAB	29	1	PIN-0_38-2_25-Z	3/8 X 2.25 CLEVIS PIN
13	1	ALA214-PLT	SPOOL	30	1	SHCS-0_25-20-0_25-Z	SOCKET HEAD 1/4-20 X 0.25
14	2	ALA21410	FLANGE BUSHING BRZ 3/8X1/2X3/8	31	2	SSCP-0_25-28-0_375	SET SCREW: 1/4-28 X 0.37
15	1	ALA67997	LIFTING STRAP	32	1	SSCP-0_375-0_912-Z	SET SCREW, 3/8-16 X 5/16" L, ZINC
16	1	BHCS-0_25-20-1_75-SS	BUTTON HEAD, 1/4-20 X 1.75, SS	33	1	WASH-0_25-0_50-0_06-SL-Z	1/4" SPLIT LOCK WASHER
17	3	BHCS-0_25-28-0_50-SS	BUTTON HEAD 1/4-28 X 0.50, SS	34	1	WASH-0_375-RH-Z	3/8 WASHER

INSTALLER EXPLODED VIEWS

AL435 SERIES ARM

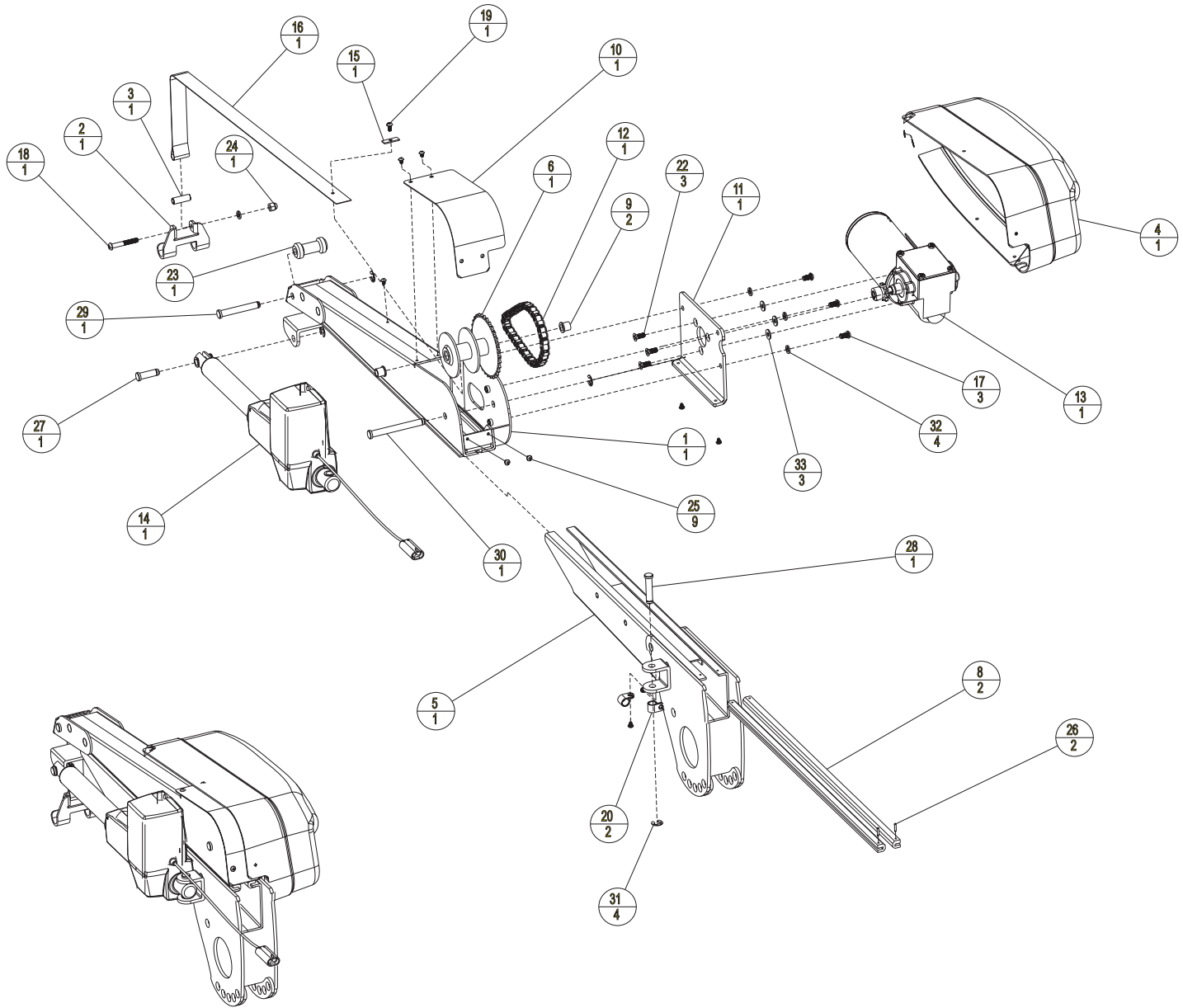

ASSEMBLY PARTS				ASSEMBLY PARTS			
ITEM	QTY	PART NO.	DESCRIPTION	ITEM	QTY	PART NO.	DESCRIPTION
1	1	280-ZB09-CC	UPPER LIFTING ARM	18	1	BHCS-0_25-20-1_75-SS	BUTTON HEAD, 1/4-20 x 1.75, SS
2	1	590-ZB01-CA	DETACHABLE HOOK	19	1	BHCS-10-32-0_37-BO	BUTTON HEAD, 10-32 x 0.37, BO
3	1	591-ZB01-CA	HOOK SLEEVE	20	2	C36001835	CLIP, "P" 1/4" (RICOH INC, EA-AMor EQ)
4	1	498-ZB09-AA	MOTOR COVER	21	1	CT-14-BLK	1/4" BLACK WIRE TIE (NOT SHOWN)
5	1	278-ZB09-CC	LOWER LIFTING ARM	22	3	FHMS-0_25-28-0_62-SS	1/4"-28 X 5/8" FLAT HEAD MACHINE SCREW
6	1	278-ZB09-AB	32 TOOTH SPOOL	23	1	H226402	AL215 & AL225 ROLLER
7	1	311-ZB09-AA	MALE TO FEMALE HARNESS (NOT SHOWN)	24	1	NUT-0_25-20-ACORN-NI	ACORN NUT, 1/4-20, NI
8	2	401-ZB09-AF	LIFTING ARM PLASTIC GUIDE	25	9	PHTS-6-32-0_25-BZ	PAN HEAD - THREAD FORMING, 6-32 X 0.25, BZ
9	2	413-3B09-AA	LIFTING SPOOL FLANGE BUSHING	26	2	PIN-0_09-0_50-RP-Z	0.09 X 0.50" ROLL PIN
10	1	530-ZB09-CD	LIFTING ARM REAR COVER	27	1	PIN-0_375-1_06-GCL-Z	ACTUATOR FRONT MOUNTING 3/8" GROOVED CLEVIS PIN
11	1	535-ZB09-CC	PC MOTOR AND COVER PLATE	28	1	PIN-0_375-1_56-GCL-Z	ACTUATOR REAR MOUNTING 3/8" GROOVED CLEVIS PIN
12	1	557-ZB09-AA	AL435/435T LIFTING CHAIN	29	1	PIN-0_375-2_41-GCL-Z	ROLLER MOUNTING 3/8" GROOVED CLEVIS PIN
13	1	703-ZB04-AB	435/435T 400lb EUCLID LIFTING MOTOR	30	1	PIN-0_375-3_31-GCL-Z	SPOOL MOUNTING 3/8" GROOVED CLEVIS PIN
14	1	800-ZB09-AB	AL435/435T ACTUATOR W/INT. SW6	31	4	RR-0_37-EC-Z	E-CLIP 3/8 SHAFIT, Z
15	1	ALA21055	STRAP TAB	32	4	WASH-0_25-0_50-0_08-SL-Z	1/4" SPLIT LOCK WASHER
16	1	ALA67997	LIFTING STRAP	33	3	WASH-0_25-0_62-0_04-RH-SS	WASHER, FLAT, 1/4", SS
17	3	BHCS-0_25-20-0_50-SS	BUTTON HEAD, 1/4-20 X 0.50, SS				

AL225, AL425 AL435, AL435T BASE

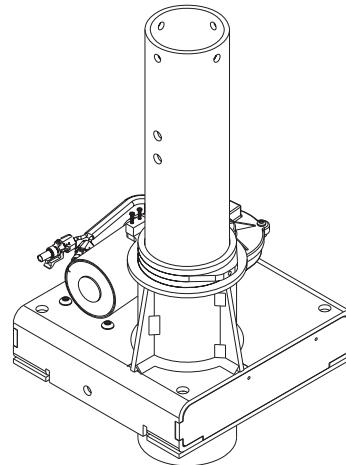
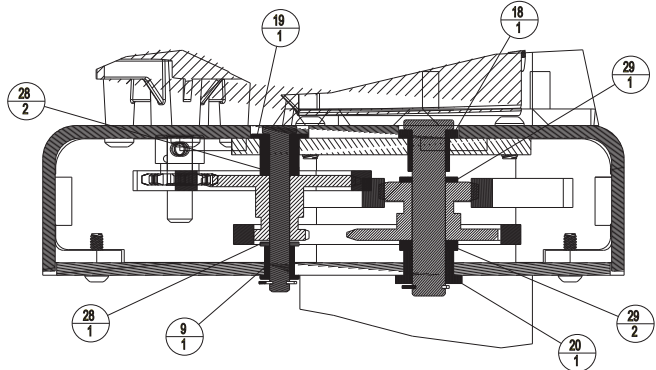
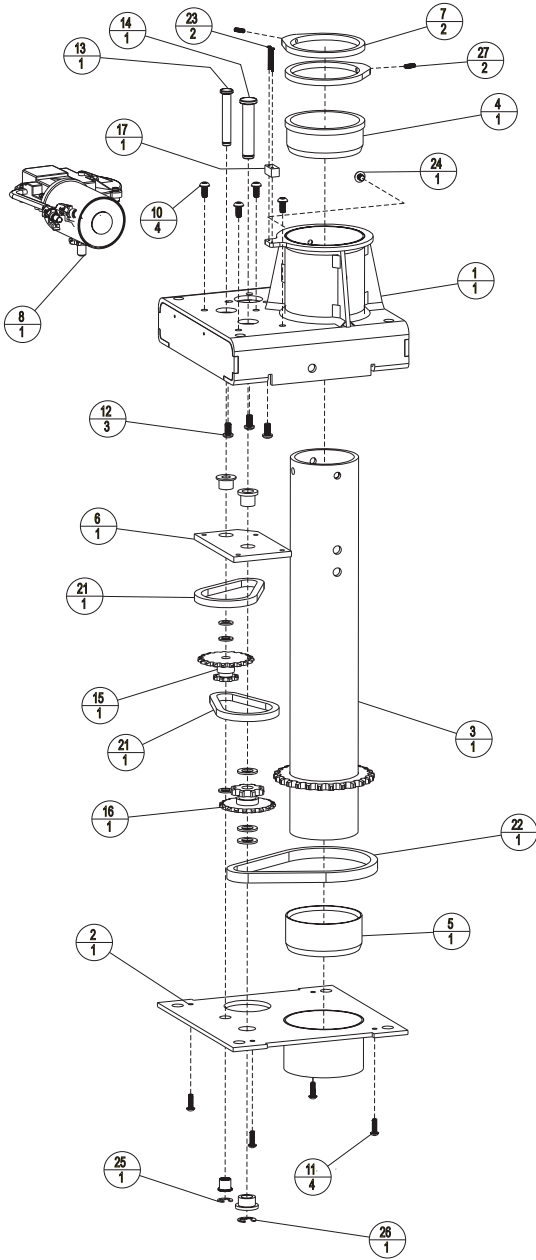

ASSEMBLY PARTS				ASSEMBLY PARTS			
ITEM	QTY	PART NO.	DESCRIPTION	ITEM	QTY	PART NO.	DESCRIPTION
1	1	201-ZB03-CE	MOTOR HOUSING	16	1	H425241	DOUBLE SPROCKET 19-35, 8-40
2	1	210-ZB03-CC	MOTOR HOUSING COVER	17	1	H425255	LIMIT/MOTOR HOUSING SPACER
3	1	220-ZB03-CD	OUTER POST TUBE	18	1	H425282	BUSHING 1/2ID,5/8OD,5/8L
4	1	400-3B01-AA	FLANGE BUSHING	19	1	H425283	BUSHING 3/8ID,5/8OD,1/2L
5	1	401-3B01-AA	CUP BUSHING	20	1	H425284	BUSHING 1/2ID,1"OD,1/2L
6	1	529-ZB03-CD	MOTOR HOUSING - GEAR PLATE	21	2	H425900	CHAIN, 35 PITCH - 26 LINKS
7	2	530-ZB03-CC	LIMIT RING	22	1	H425901	CHAIN, 40 PITCH - 33 LINKS
8	1	700-1D02-AB	MOTOR, ANKARSRUM, KSV 4030-822	23	2	PHMS-2-56-1_00-SS	PAN HEAD, #2-56 X 1.00, SS
9	1	ALA21411	FLANGE BUSHING BRZ 3/8X1/2X1/2	24	1	RHSS-0_25-20-0_25-N	ROUND HEAD, 1/4-20 x .25" NYLON
10	4	BHCS-0_25-20-0_50-SS	BUTTON HEAD, 1/4-20 X 0.50, SS	25	1	RR-0_37-EC-Z	E-CLIP 3/8 SHAFT, Z
11	4	BHCS-10-24-0_50-NP-SS	BUTTON HEAD, 10-24 X 0.50 W/ NYLON PATCH, SS	28	1	RR-0_50-EC-Z	E-CLIP 1/2 SHAFT, Z
12	3	BHCS-M6-1_00-16-SS	BUTTON HEAD, M6-1 X 16MM, SS	27	2	SSCP-8-32-0_50-SS	SET SCREW, 8-32 X 0.50, SS
13	1	H425231	MOTOR HOUSING GEAR PIN - A	28	3	WASH-0_37-0_62-0_06-RH-SS	WASHER, 3/8" ID x 5/8" OD x 0.06" THICK, 18-8SS
14	1	H425232	MOTOR HOUSING GEAR PIN - B	29	3	WASH-0_50-0_88-Z	WASHER, 1/2" ID x 7/8" OD x 0.075" THICK, ZP
15	1	H425240	DOUBLE SPROCKET 19-35, 8-35				

INSTALLER EXPLODED VIEWS

AL425HD BASE

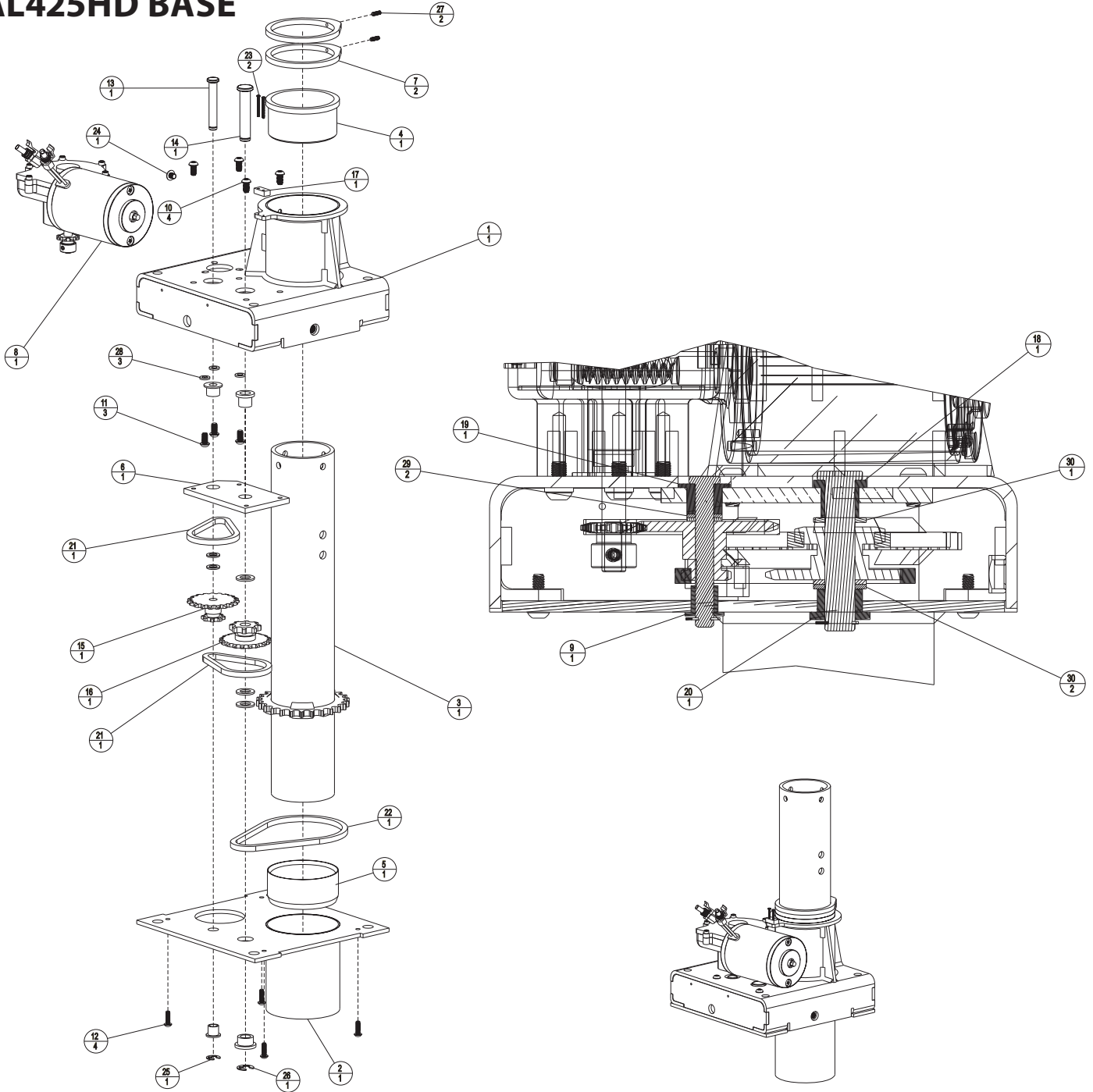

ASSEMBLY PARTS				ASSEMBLY PARTS			
ITEM	QTY	PART NO.	DESCRIPTION	ITEM	QTY	PART NO.	DESCRIPTION
1	1	201-ZB03-CE	PC MOTOR HOUSING	16	1	H425241	DOUBLE SPROCKET 19-35, 8-40
2	1	250-ID05-CA	MOTOR HOUSING COVER WELD	17	1	H425255	AL425435 LIMIT SWITCH SPACER
3	1	255-ID05-CB	PC OUTER POST TUBE	18	1	H425262	BUSHING BRONZE 1/2 ID x 5/8" OD x 5/8" OAL
4	1	400-3B01-AA	FLANGE BUSHING	19	1	H425263	BEARING FLANGE, 3/8" ID x 7/8" OD x 1/2" OAL
5	1	401-3B01-AA	CUP BUSHING	20	1	H425264	BUSHING FLANGE, BRONZE 1/2 ID x 1" OD x 1/2" OAL
6	1	529-ZB03-CD	MOTOR HOUSING - GEAR PLATE	21	2	H425800	35 PITCH CHAIN LOOP, 28 LINKS
7	2	630-ZB03-CC	LIMIT RING	22	1	H425801	40 PITCH CHAIN LOOP, 33 LINKS
8	1	700-3B03-AC	MOTOR, 12VDC, MD ROTATIONAL	23	2	PHMS-2-56-1_00-SS	MS #2-56 X 1.00
9	1	ALA21411	BEARING FLANGE, 3/8" ID x 1/2" OD x 1/2" OAL	24	1	RHSS-0_25-20-0_25-N	1/4-20 x .25" NYLON Flat Head
10	4	BHCS-0_25-20-0_50-SS	BHCS 1/4-20 X 0.50	25	1	RR-0_37-EC-Z	E-CLIP 3/8 SHAFt OD
11	3	BHCS-0_25-28-0_50-SS	BUTTON HEAD 1/4-28 x 0.50, SS	26	1	RR-0_50-EC-Z	E-CLIP 1/2 SHAFt OD
12	4	BHCS-10-24-0_62-BO	SCS 10-24 X 5/8	27	2	SSCP-8-32-0_50-SS	SET SCREW 8-32 X 0.50
13	1	H425231	MOTOR HOUSING GEAR PIN - A	28	3	WASH-0_25-0_50-0_06-SL-Z	1/4" SPLIT LOCK WASHER
14	1	H425232	MOTOR HOUSING GEAR PIN - B	29	2	WASH-0_37-0_62-0_06-RH-SS	WASHER, 3/8" ID x 5/8" OD x 0.06" THICK, 18-8SS
15	1	H425240	DOUBLE SPROCKET 19-35, 8-35	30	3	WASH-0_50-0_88-Z	WASHER, 1/2" ID x 7/8" OD x 0.075" THICK, ZP

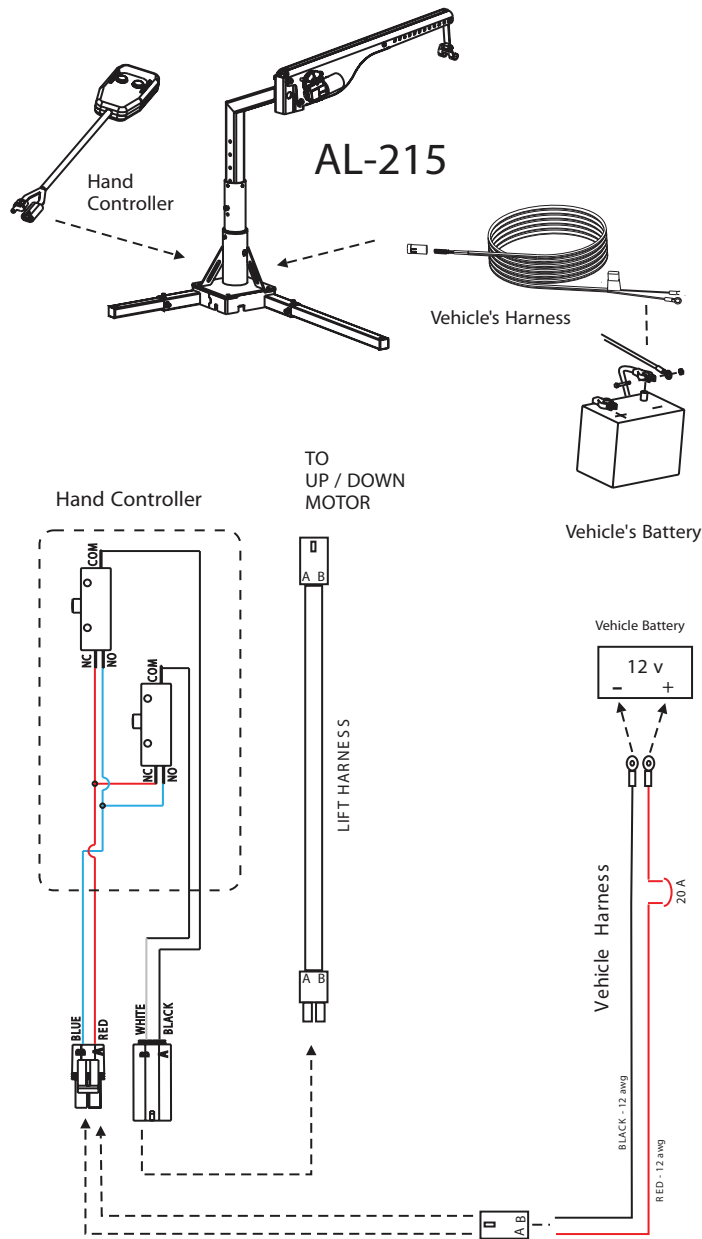

KIT 390-00032 INCLUDES:

- 1 - 380-00056 - LIFT HARNESS
- 1 - 380-00055 - LIMIT HARNESS
- 1 - 380-00054 - ROTATION HARNESS
- 1 - 360-00052 - POWER / CONTROL HARNESS

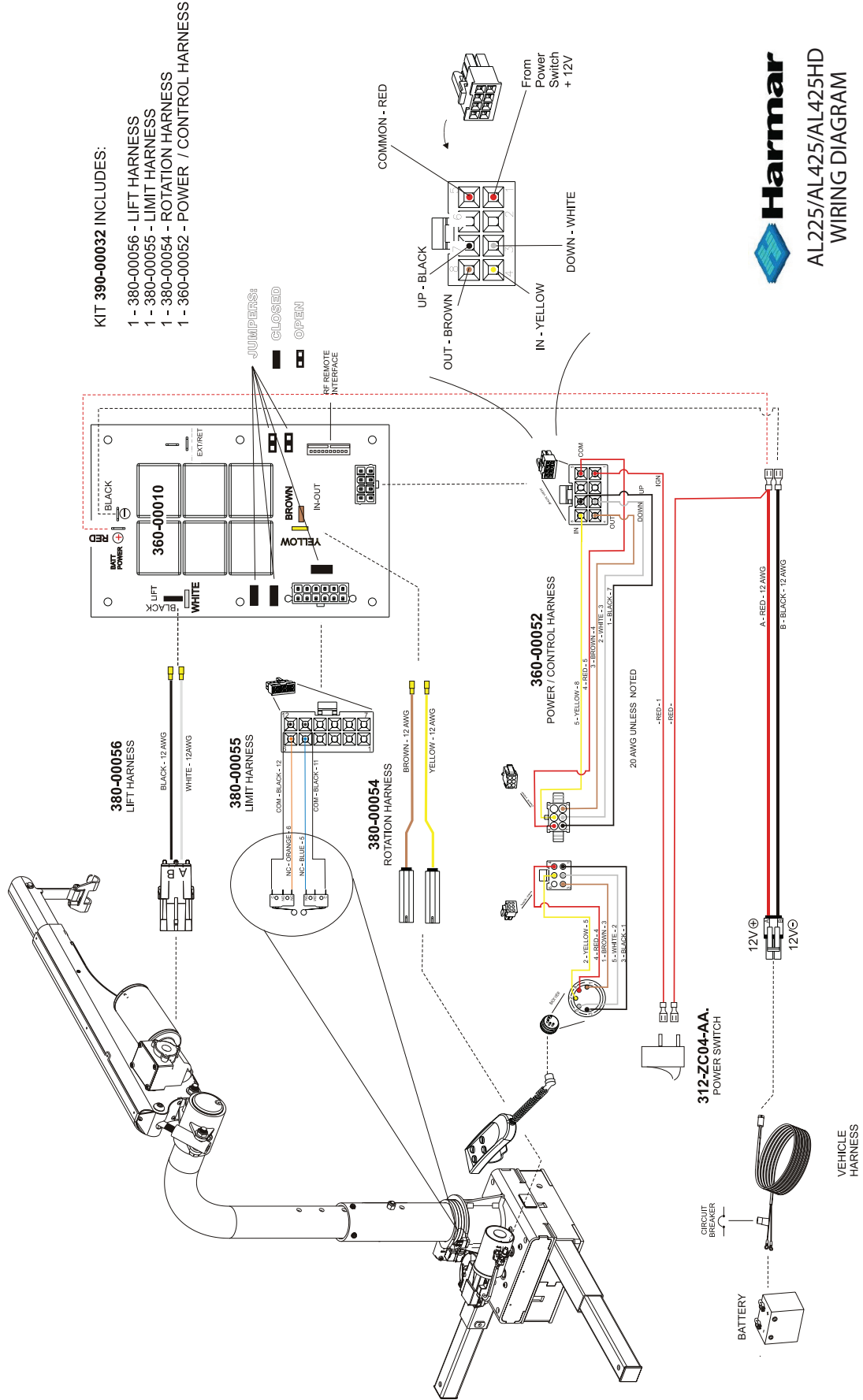

AL225/AL425/AL425HD WIRING DIAGRAM

650-00003



AL435 / AL435T WIRING DIAGRAM

650-00006

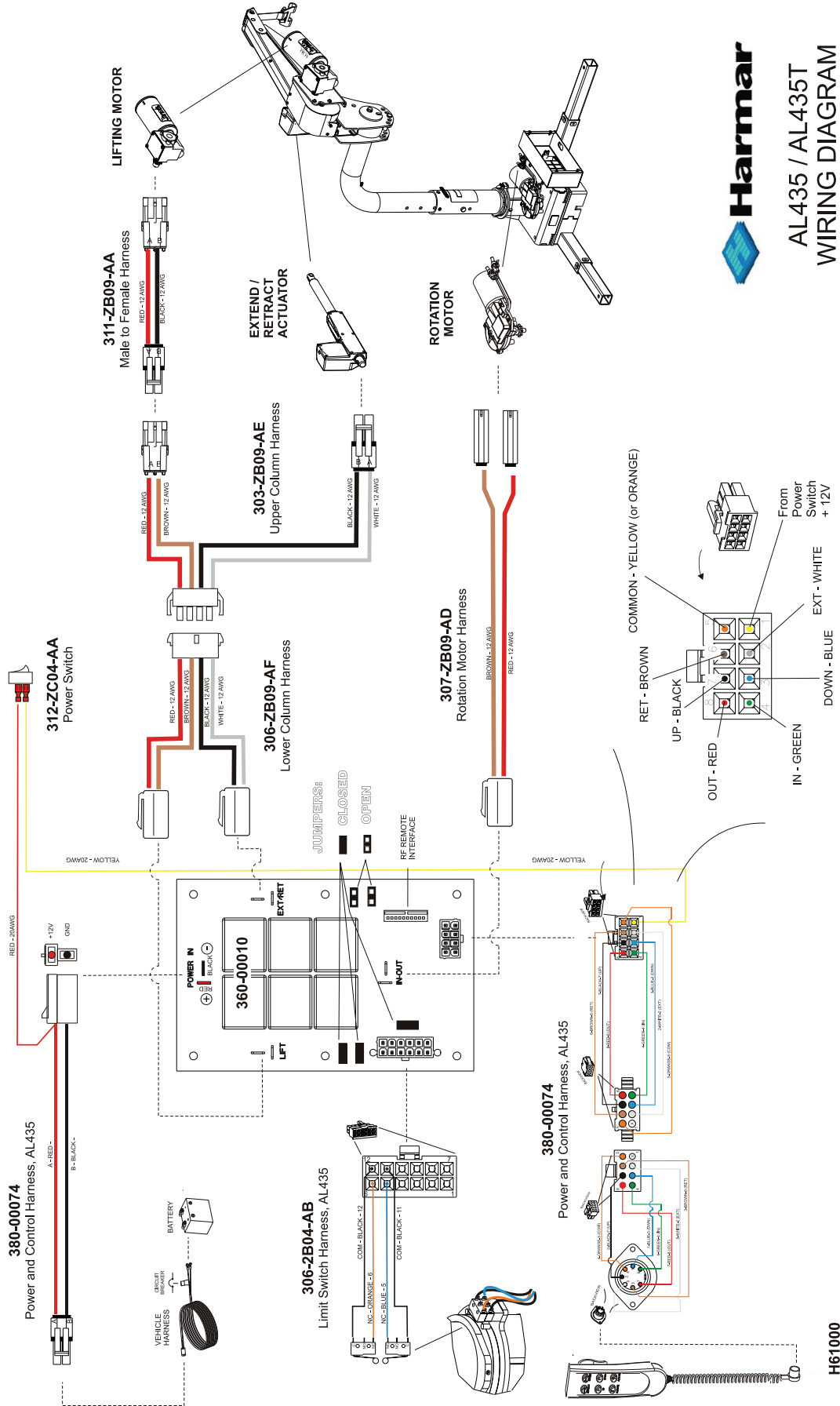



VEHICLE LIFT THREE YEAR TRANSFERABLE WARRANTY

LIMITED WARRANTY CERTIFICATE

Harmar warrants to the owner of the Vehicle Lift manufactured by us to be free from defects in material, mechanical and electrical components (parts) for a period of three (3) years, provided that the products have been installed, maintained and operated properly by an Authorized Harmar Distributor or Certified Harmar Installer.

This warranty starts on the date of initial product installation (not to exceed 180 days from the date of manufacture), provided the warranty certificate is completely filled out and returned to Harmar within ten (10) days of installation. Harmar warrants its lift product against defects in material, mechanical and electrical components (parts), excluding labor cost, batteries, paint, rust and covers, for a period of three (3) years from date of retail purchase, provided that the products have been installed, maintained and operated properly. Harmar and its dealers shall not be liable for any consequential, special or incidental damages arising out of the purchase or use of the unit or resulting from the breach of this Limited Warranty, or any implied warranty. This warranty is transferable as long as the application is approved by Harmar's Compatibility Calculator.

This warranty does not cover defects in vehicles on which Harmar products are installed or malfunctions in Harmar products caused by defects in any part of the vehicle upon which the product is installed. This warranty does not cover maintenance or adjustments. The limit of liability of Harmar and its dealer hereunder shall be the unit's purchase price. Some states do not allow limitations on how long an implied warranty lasts or the exclusion or limitation of incidental or consequential damages, or legal remedies, so these above limitations may not apply. All warranty claims must be reported to the dealer from whom the lift was purchased as they have responsibility for handling warranty claims. Applications involving vehicles or mobility devices not approved by Harmar's Compatibility Calculator will void the warranty.

The dealer is to contact the Technical Services Department of Harmar and provide the serial number of the product along with a description and evidence of the defect(s) supporting a warranty claim. Dealers may charge for labor, service, travel, or other associated costs to make repairs, and such charges are not covered by this Limited Warranty. It is permissible to have any repairs or replacement work done as a result of any defects in material and workmanship by someone other than the Dealer under this Limited Warranty.

However, the Limited Warranty does not cover any charges or expenses assessed by any such other person or company performing such repairs or replacement work. All parts used to replace defective materials must be genuine Harmar parts to be covered by this Limited Warranty. This Limited Warranty grants specific legal rights, other rights vary from state to state. Harmar will not be charged for labor, consequential damage or repair expenses. Harmar will not, under any circumstances, be liable for the loss of the use of its products or loss of time. Defective parts must be returned, if requested, prepaid, to Harmar for inspection prior to credit or replacement. At Harmar's discretion, any part found to have been modified, over-stressed, damaged by accident, or misused is not covered by this warranty.

THIS WARRANTY IS IN LIEU OF ALL OTHER WARRANTIES OR CONDITIONS, INCLUDING ALL IMPLIED WARRANTIES OR MERCHANTABILITY OR FITNESS FOR A PARTICULAR PURPOSE, AND THERE ARE NO WARRANTIES THAT EXTEND BEYOND THE DESCRIPTION OF THE LIMITED WARRANTY DESCRIBED HEREIN.

Inside Lifts

Installation & Owner's Manual



Harmar[®]
Lifts for Life

www.harmar.com | 800-833-0478

2075 47th Street Sarasota, Florida 34234