



VEGEGA.

**A COMPLETE GUIDE
TO START
YOUR GARDENING**



www.vegega.com

ABOUT US

To create a natural, healthy and eco-friendly garden is our brand concept. One of VEGEGA top priorities is to serve its customers and to provide Zn-Al-Mg Steel modular raised garden beds to our customers, help you build an appealing garden in an easy way as well as give you and your family a happy gardening experience.

Zn-Al-Mg Steel material for raised garden beds has the following significant advantages:

- **Hard metal panels will not be damaged by pests and mice.**
- **Eco-friendly material**
- **Easy to assemble**
- **High tear resistance**
- **Long-lasting and durable, up to 20+ years**
- **High/low-temperature resistant from -148°F to 200°F**
- **Less bending down**
- **Safe and no soil contamination**
- **Grow much more in much less space**



TABLES OF CONTENTS

1

Instruction Guide 1

2

How to Fill the bed 3

3

Assembly Instruction 5

9 in 1 6

6 in 1 8

4 in 1 10

2 in 1 12

10 in 1 13

Round 14

Special Shapes 15

Extension Kit 31

4

Certification 32

INSTRUCTION GUIDE

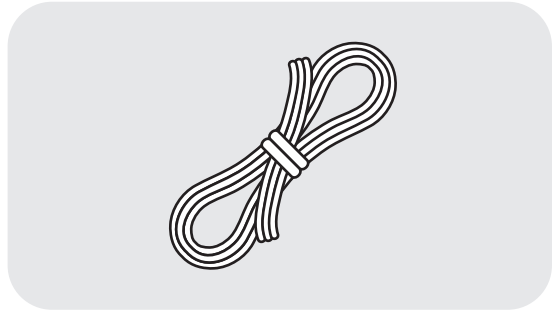
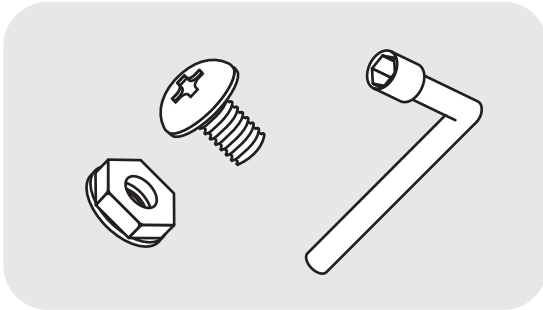

- 1.** Start removing film horizontally.

- 2.** Keep holes aligned between two panels.



- 3.** Put the screws through the hole, place the washers(inside) and nuts. Use the wrench to tight up.

INSTRUCTION GUIDE

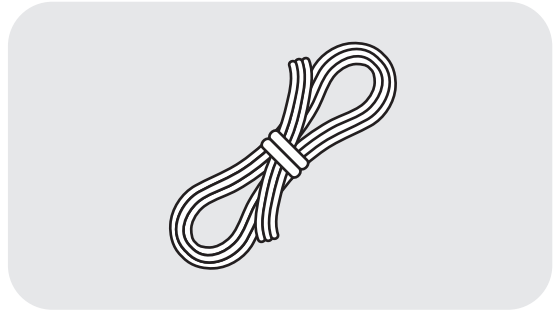
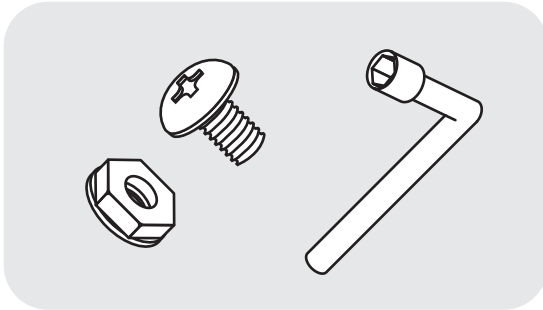

4. Place the bracing rods. For more details on how to install the rods, please see Page 23.

5.
Apply protective rubber edging and push it down.



6. Done!

HOW TO FILL THE BED

Calculate Soil Volume

Formula:

Length × Width × Height/Depth

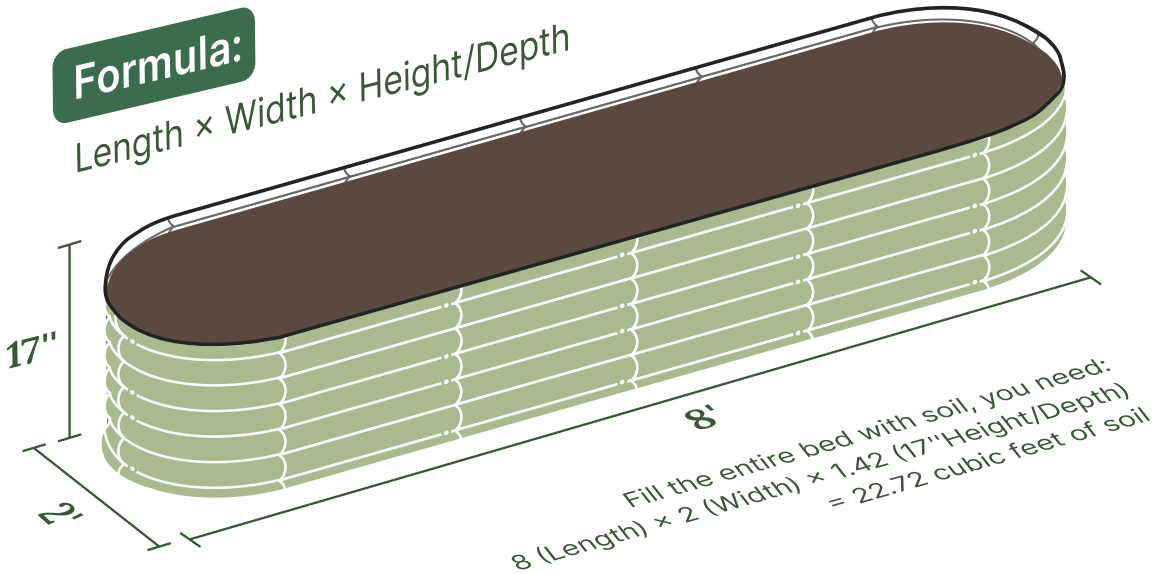

How Deep Should My Soil Be in the Garden Beds?

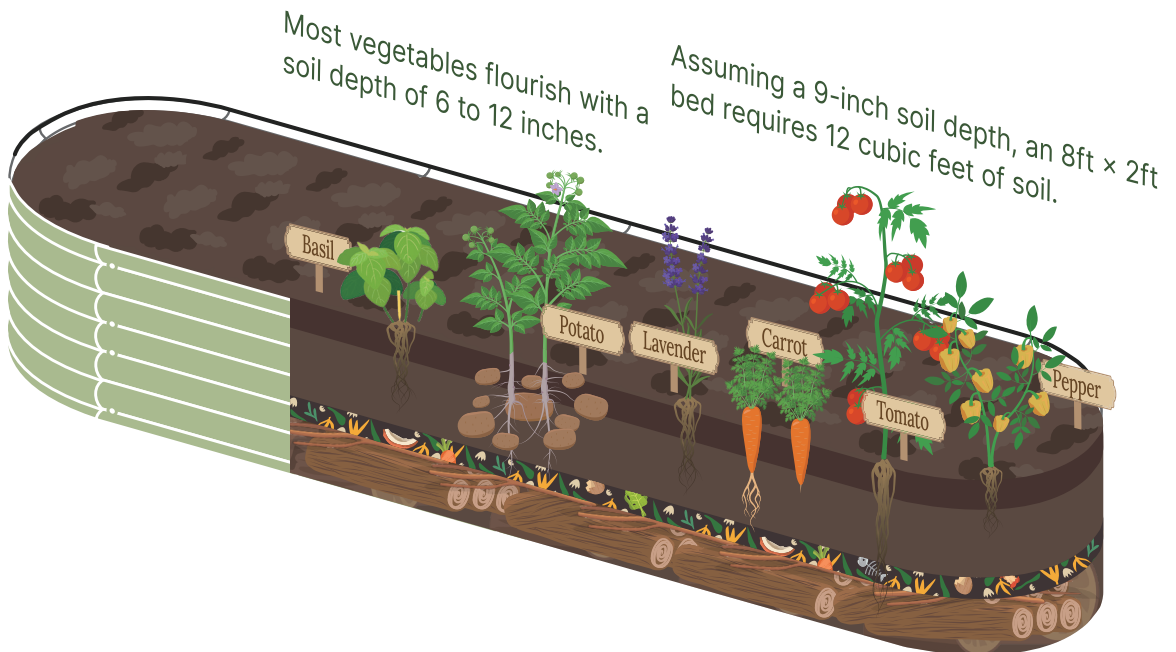

HOW TO FILL THE BED

Soil Type And Mix for the Raised Garden Bed

Soil Types for Garden Beds



Topsoil

Rich mineral



Potting Mix

Mix of peat moss, vermiculite, and perlite



Compost Soil

Lighter than topsoil but is bursting with nutrients

Soil Mix for Garden Beds

$\frac{1}{3}$ Peat Moss

Moisture retention and keeping soil aerated

$\frac{1}{3}$ Vermiculite

Enhancing drainage performance

$\frac{1}{3}$ Compost

A hotbed for beneficial microorganisms

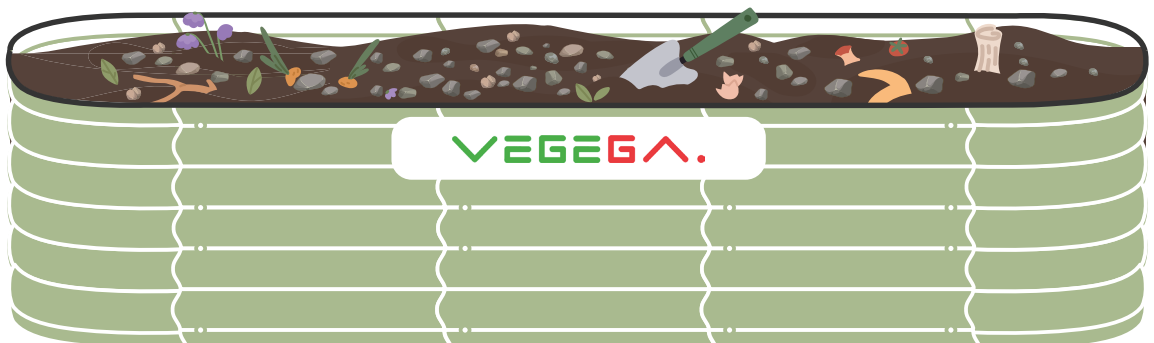

ASSEMBLY INSTRUCTION

9 in 1 Size: 8'x2'

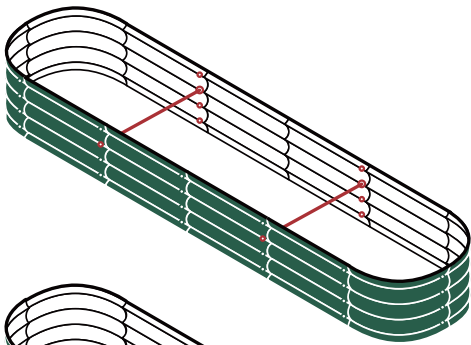
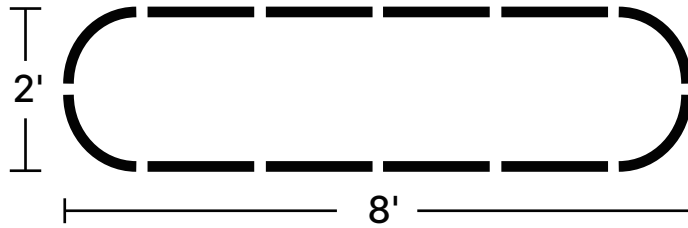

11"

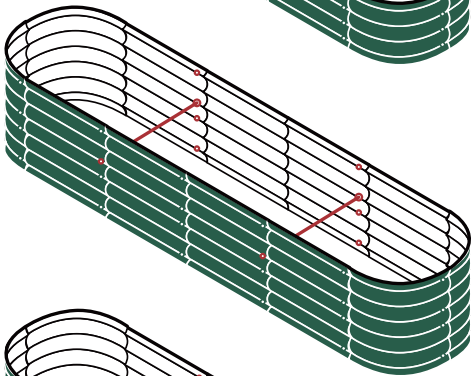
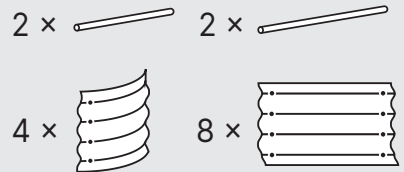

17"

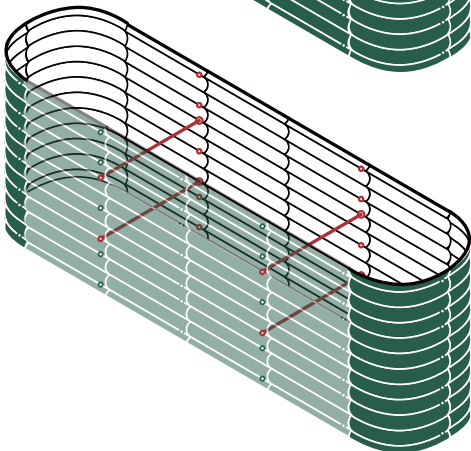
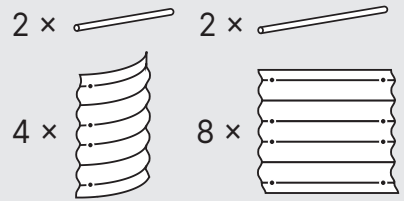

32"

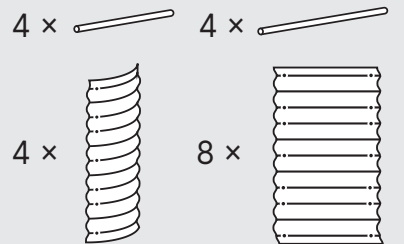

ASSEMBLY INSTRUCTION

9 in 1 Size: 6.5'x3.5'

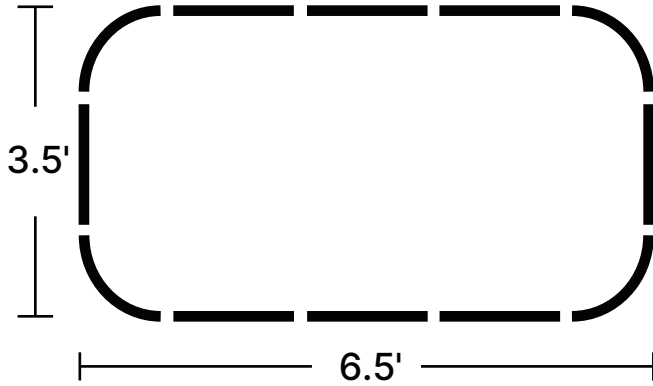

*3.5ft rod is combined by one 2ft rod and one 1.5ft rod

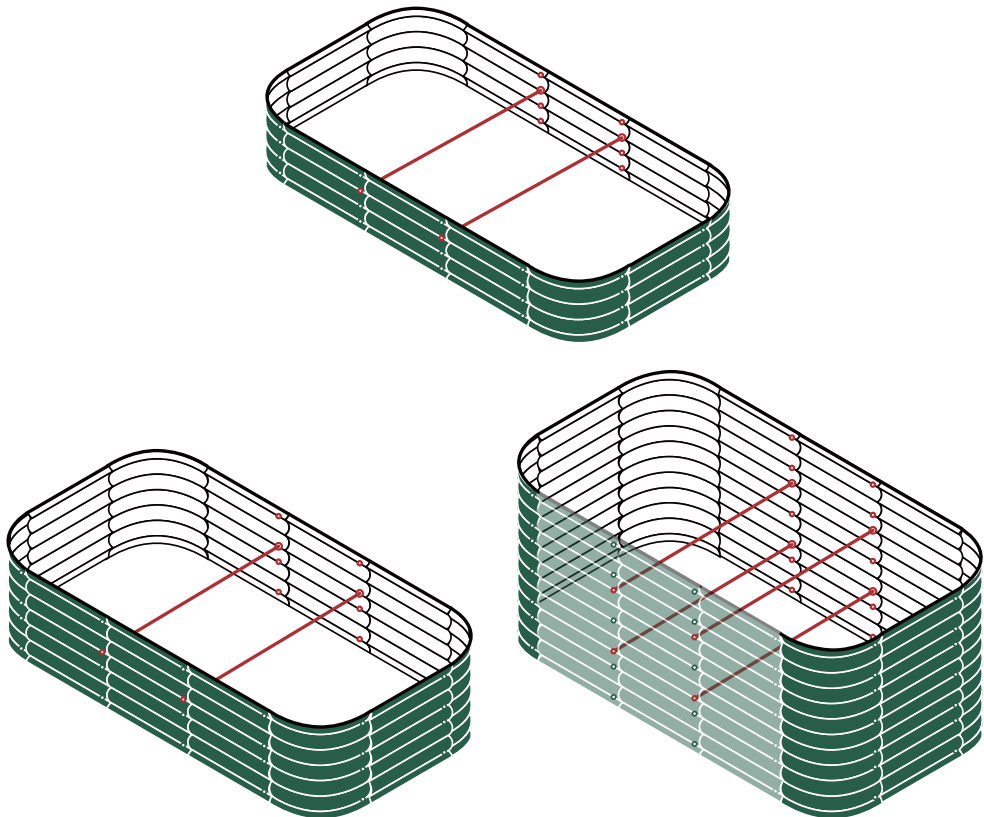
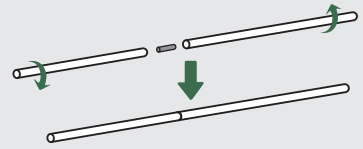

ASSEMBLY INSTRUCTION

9 in 1 Size: 5'x5'

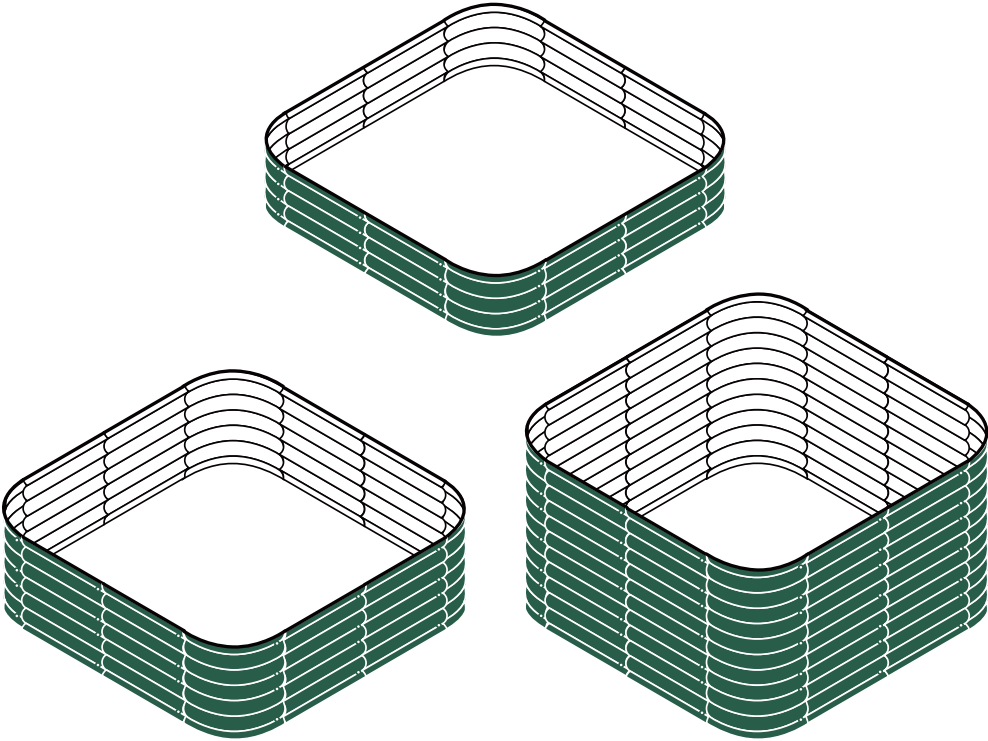
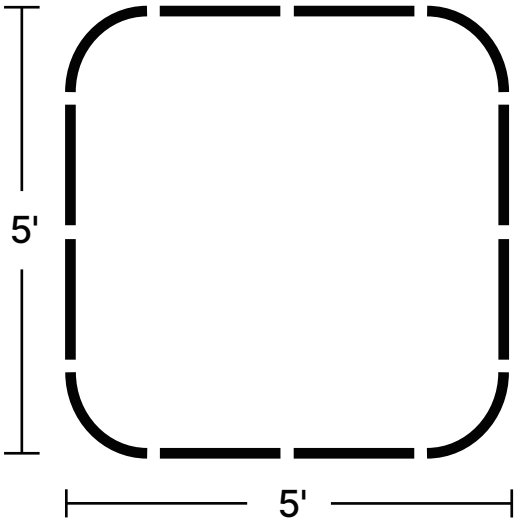

ASSEMBLY INSTRUCTION

6 in 1 Size: 6.5'x2'

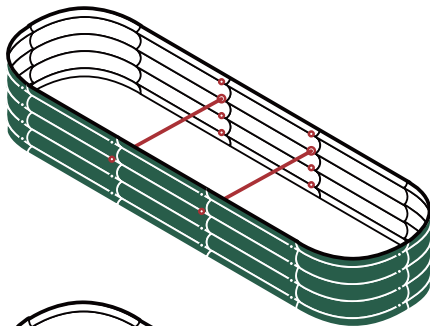
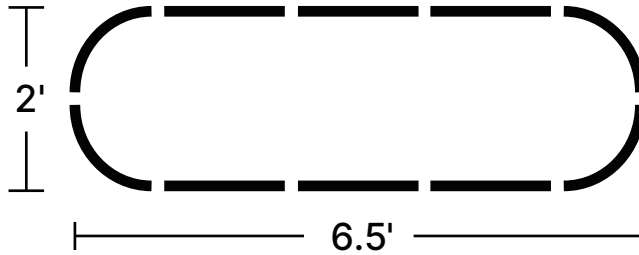

11"

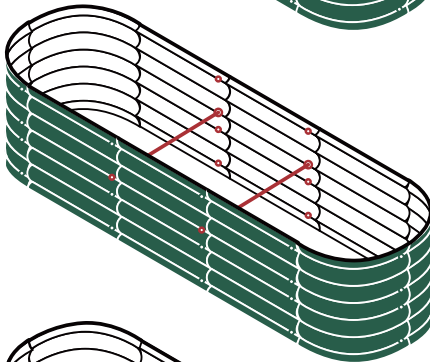
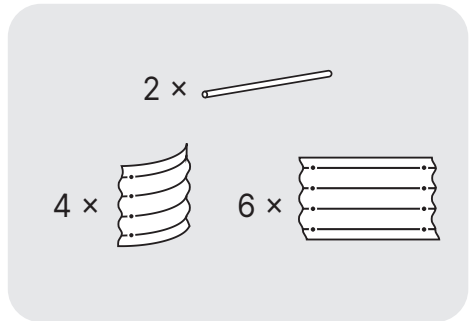

17"

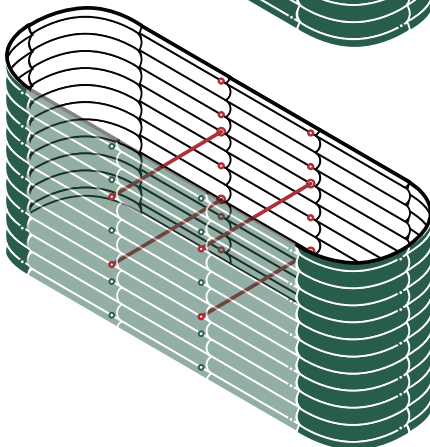
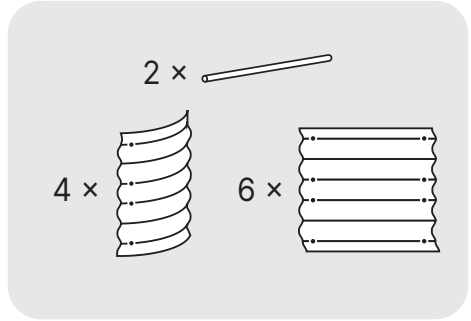

32"

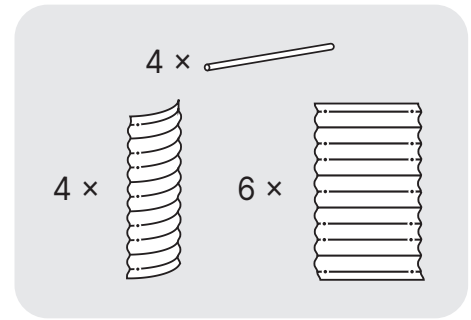

ASSEMBLY INSTRUCTION

6 in 1 Size: 5'×3.5'

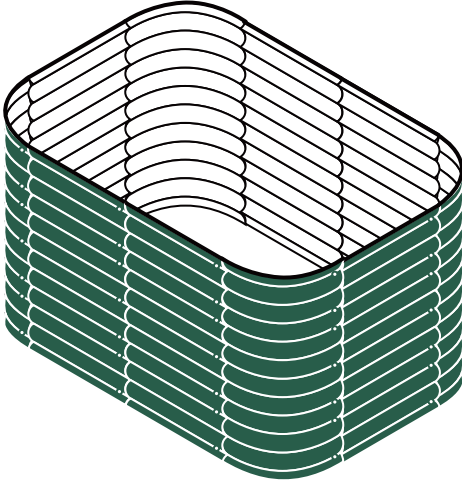
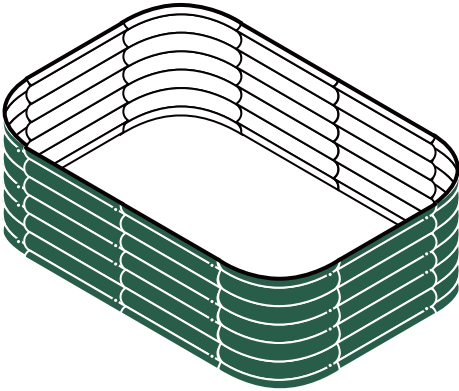
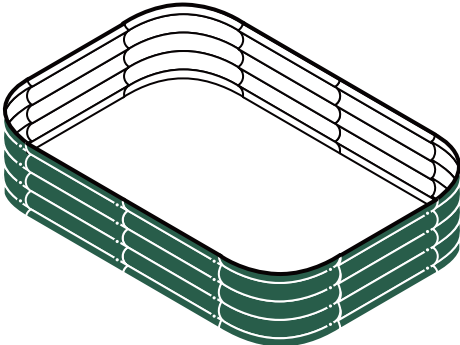
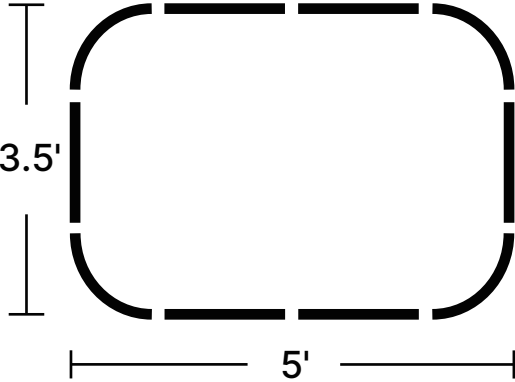

ASSEMBLY INSTRUCTION

4 in 1 Size: 5'x2'

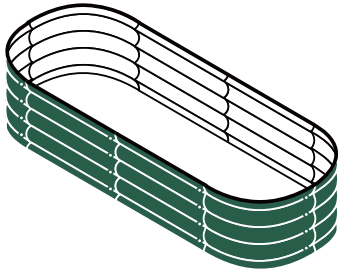
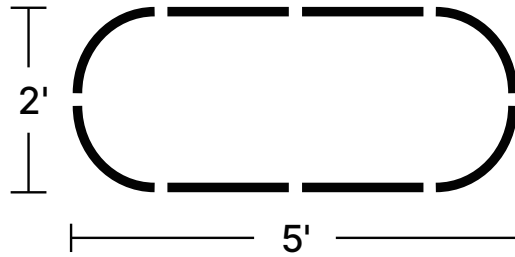

11''

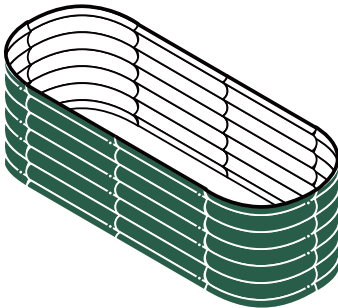
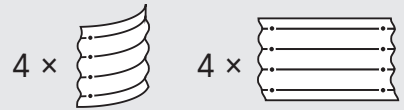

17''

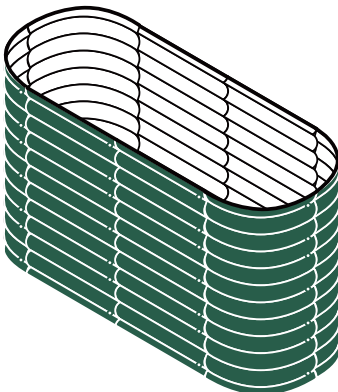
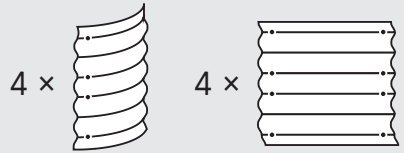

32''

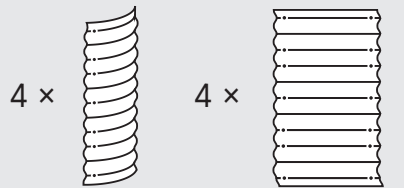

ASSEMBLY INSTRUCTION

4 in 1 Size: 3.5'x3.5'

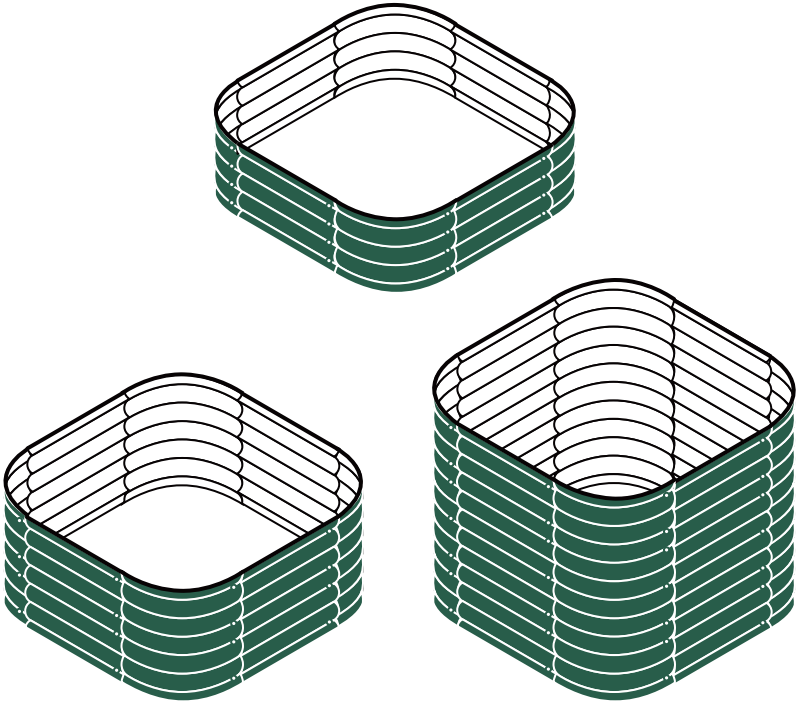
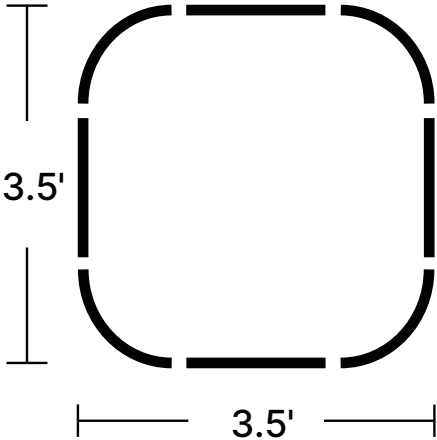

ASSEMBLY INSTRUCTION

2 in 1 Size: 3.5'x2'

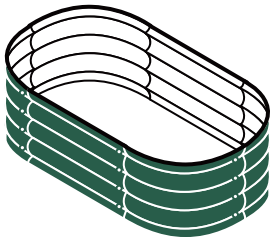
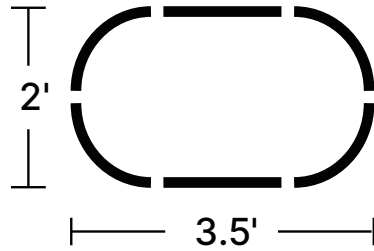

11"

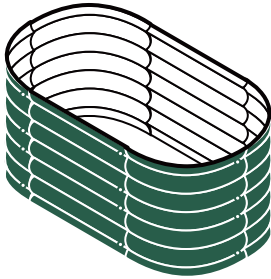
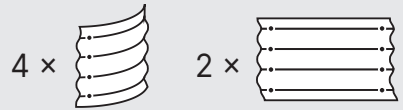

17"

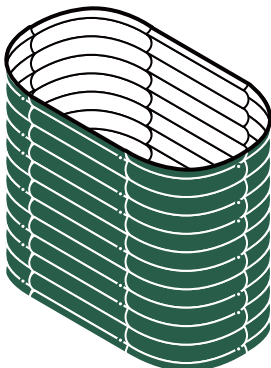
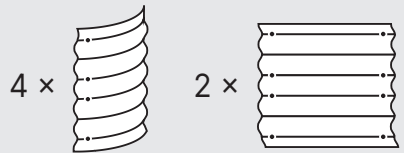

32"

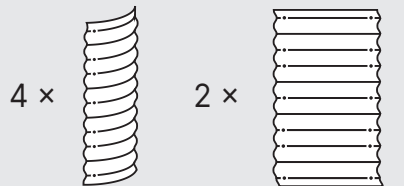

ASSEMBLY INSTRUCTION

10 in 1

■ 1.5 ft
■ 2 ft

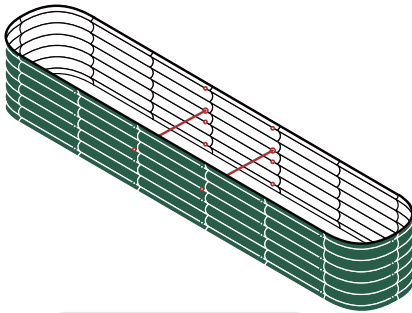
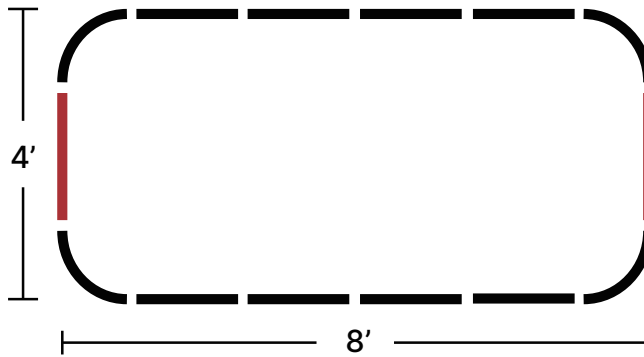
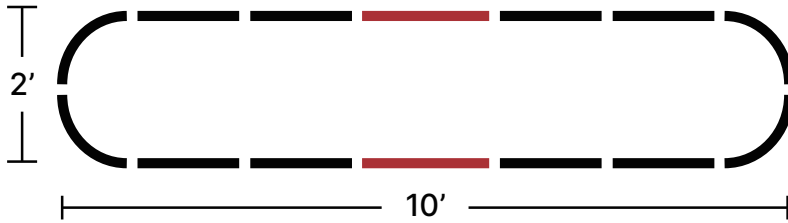

2 ×  (2 ft)

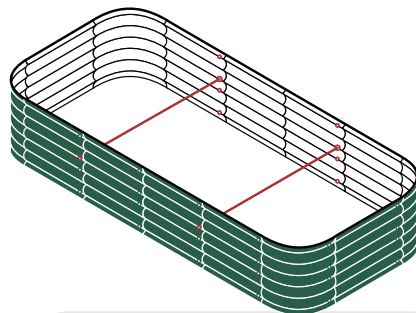

2 ×  (1.5 ft)
2 ×  (2.5 ft)

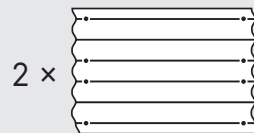

ASSEMBLY INSTRUCTION

24" Round

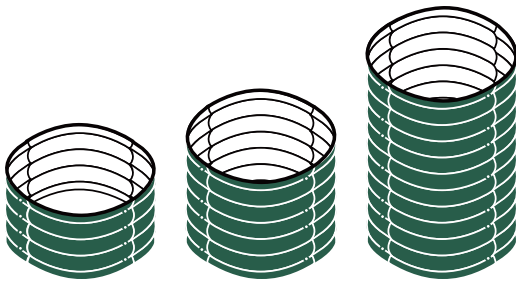
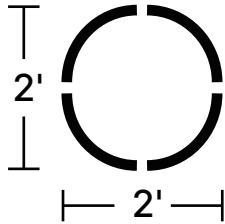

11"

4 ×



17"

4 ×



32"

4 ×



42" Round

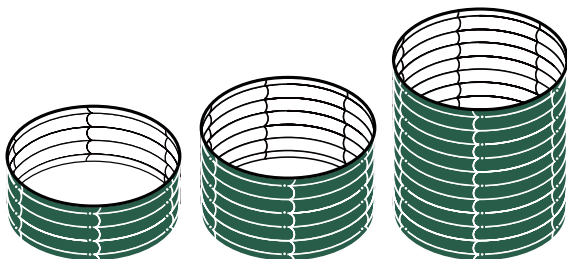
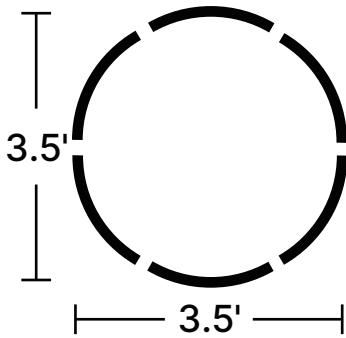

8"

6 ×



17"

6 ×



32"

6 ×

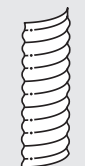

ASSEMBLY INSTRUCTION

SPECIAL SHAPES

Rectangle

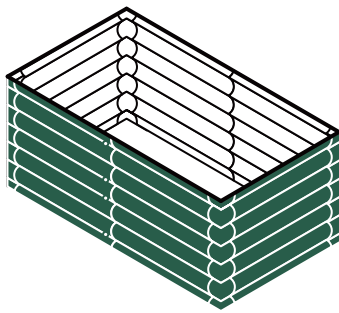
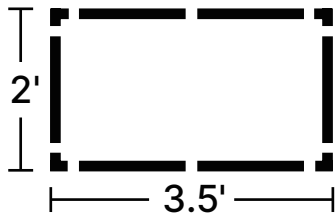

4 ×



6 ×

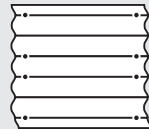

Square

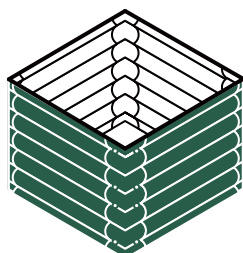
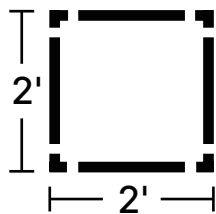

4 ×



4 ×

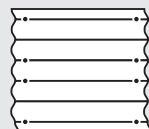

ASSEMBLY INSTRUCTION

SPECIAL SHAPES

17" Tall 9 in 1 Rectangle

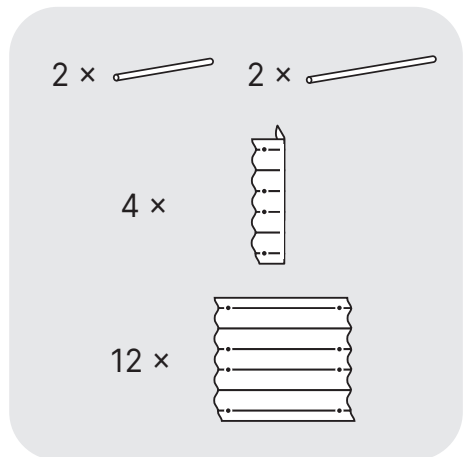
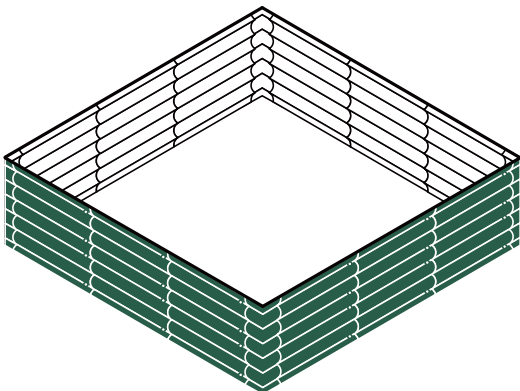
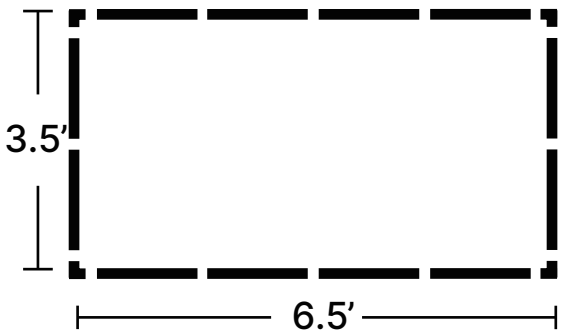
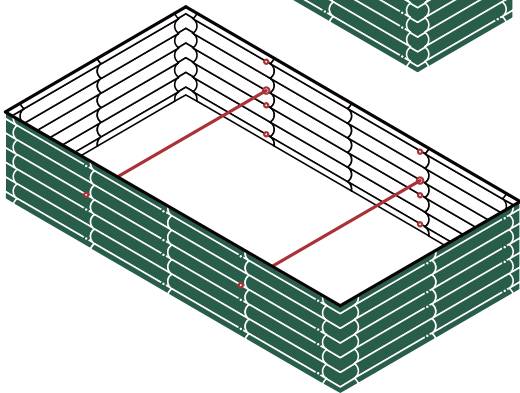
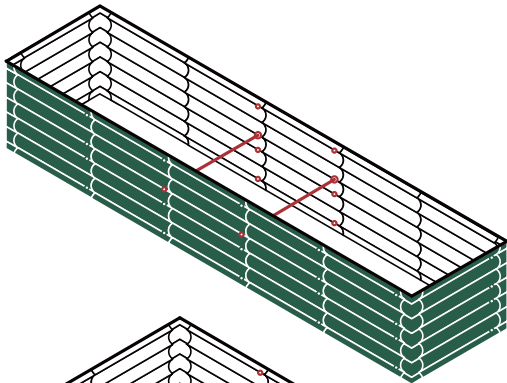
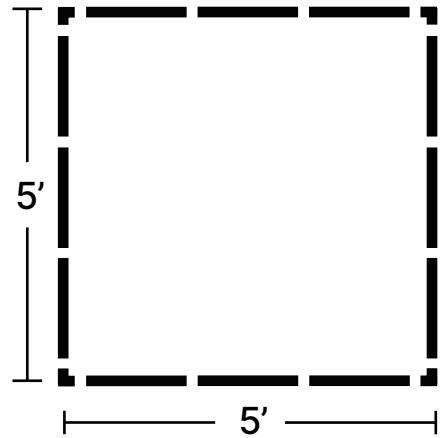
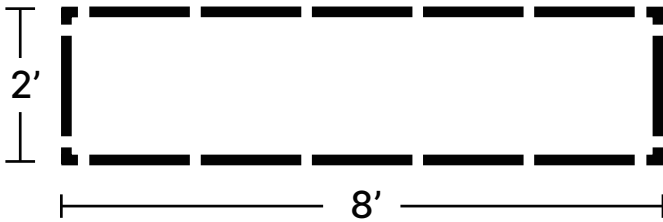

ASSEMBLY INSTRUCTION

SPECIAL SHAPES

17" Tall 6 in 1 Rectangle

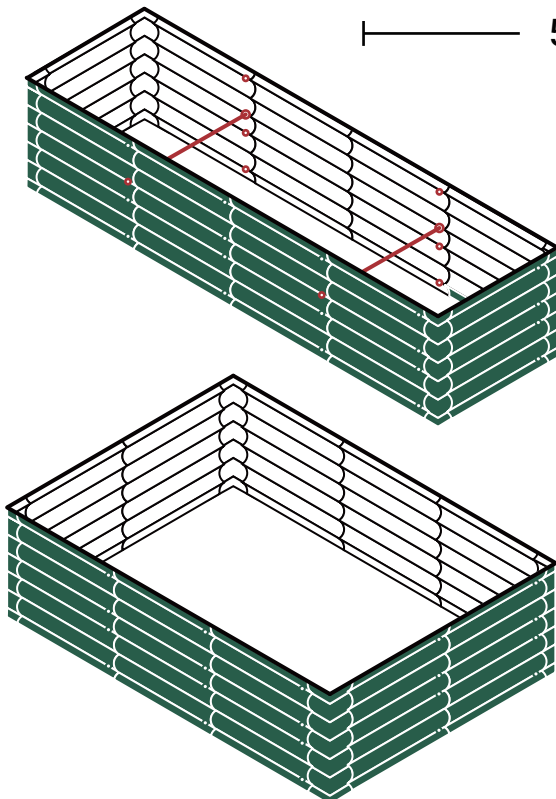
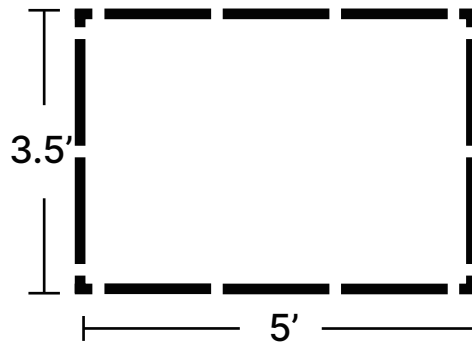
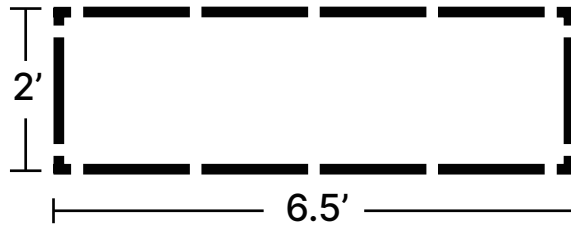

2 × 

4 × 

10 × 

ASSEMBLY INSTRUCTION

SPECIAL SHAPES

Pentagon

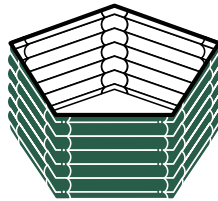
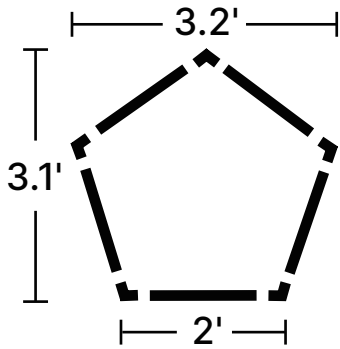

5 ×



5 ×

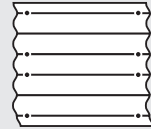

Hexagon

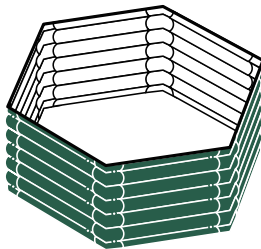
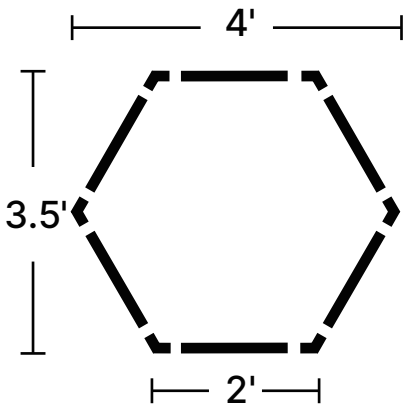

6 ×



6 ×

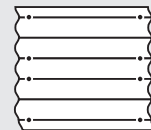

ASSEMBLY INSTRUCTION

SPECIAL SHAPES

Tiered

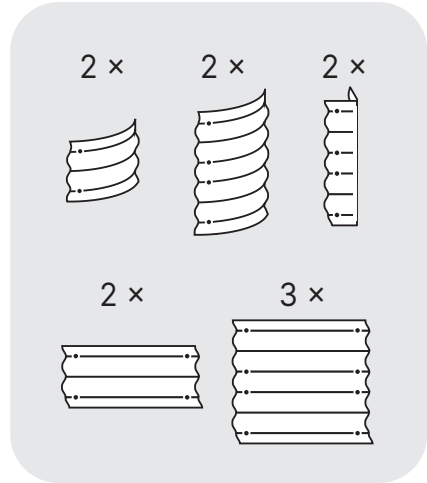
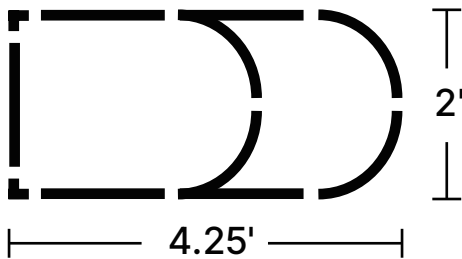

①



Assemble one 8" side panel and one 8" corner panel.

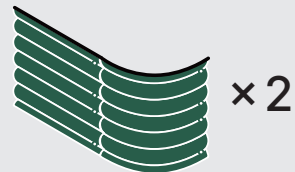

Assemble one 17" side panel and one 17" corner panel.

②

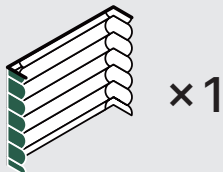

Assemble one 17" side panel and 2 pcs of straight corner panels.

③

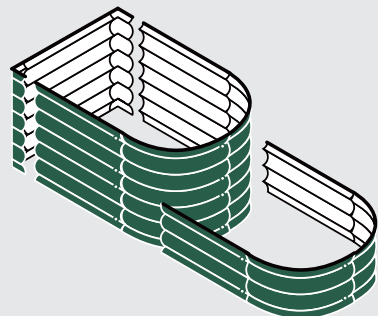

Put them together as shown on the picture.

ASSEMBLY INSTRUCTION

SPECIAL SHAPES

Castle

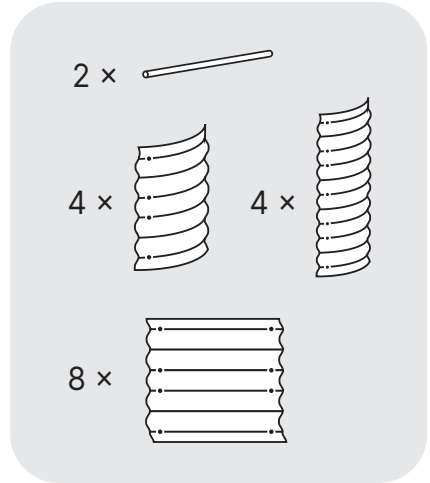
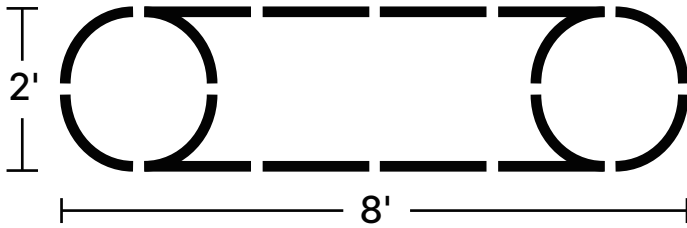

①

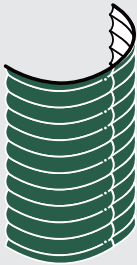

× 2
Assemble two 32"
corner panels.



× 2
Assemble two 17"
corner panels.

②

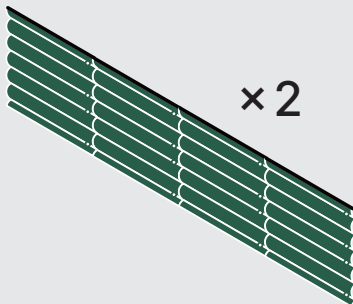

× 2
Assemble four 17" side panels.

③

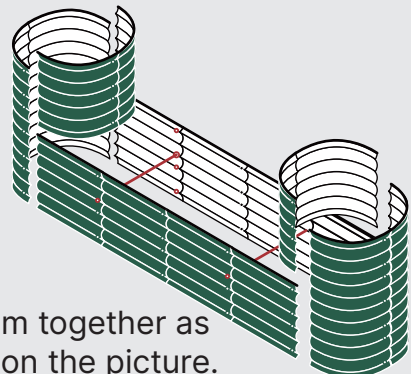

Put them together as
shown on the picture.

ASSEMBLY INSTRUCTION

SPECIAL SHAPES

Heart Shaped

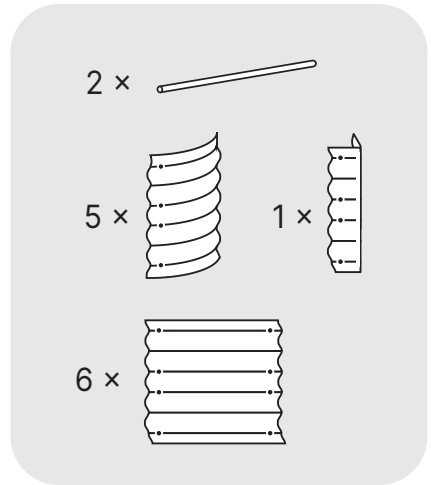
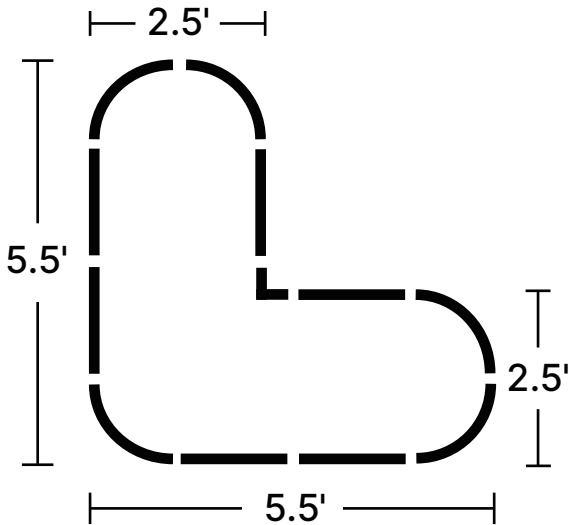

①

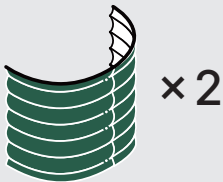

Assemble two corner panels.



One corner panel



One straight corner panel.

②

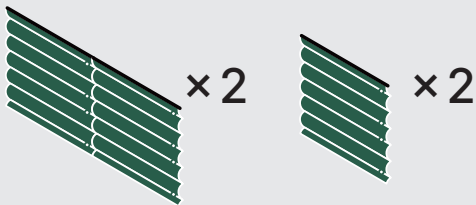

Assemble two side panels.

One side panel

③

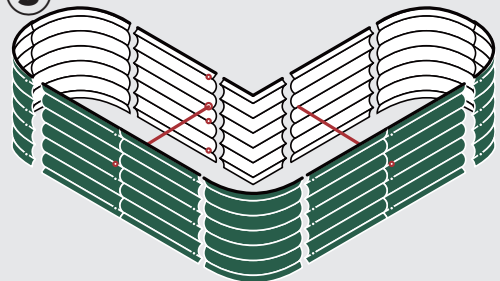

Put them together as shown on the picture.

ASSEMBLY INSTRUCTION

SPECIAL SHAPES

L Shaped

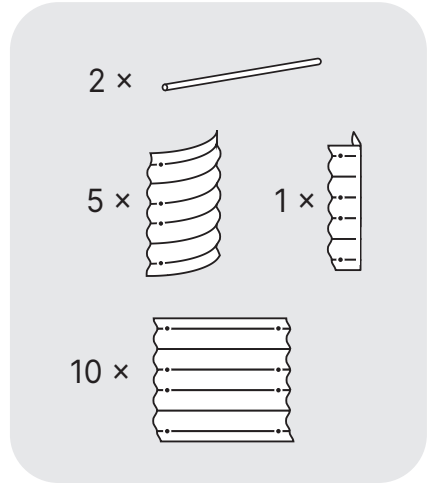
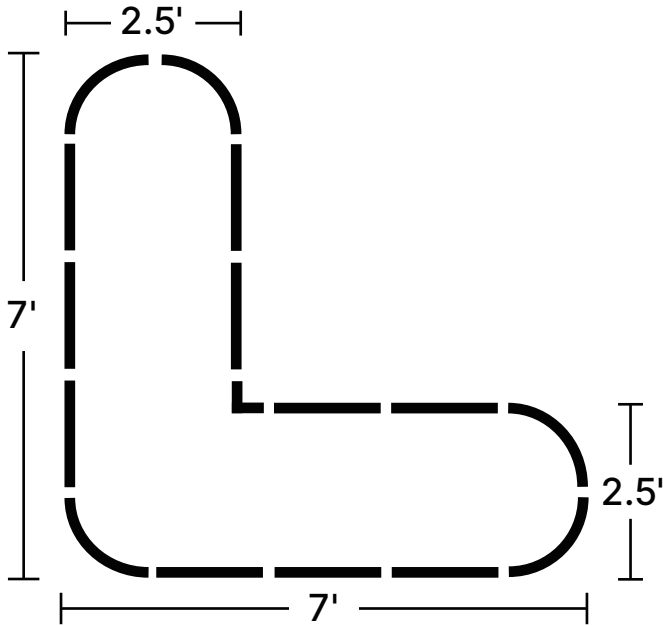

①

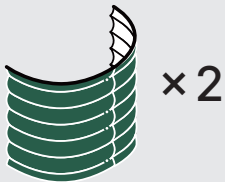

Assemble two corner panels.



One corner panel



One straight corner panel

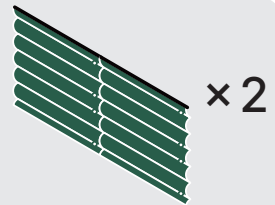

Assemble two side panels.

②

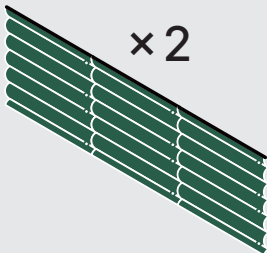

Assemble three side panels.

③

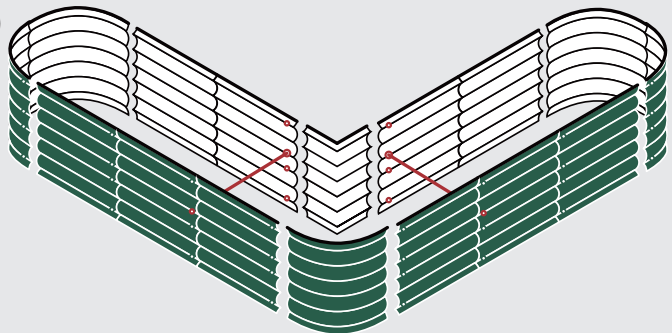

ASSEMBLY INSTRUCTION

SPECIAL SHAPES

U Shaped Standard

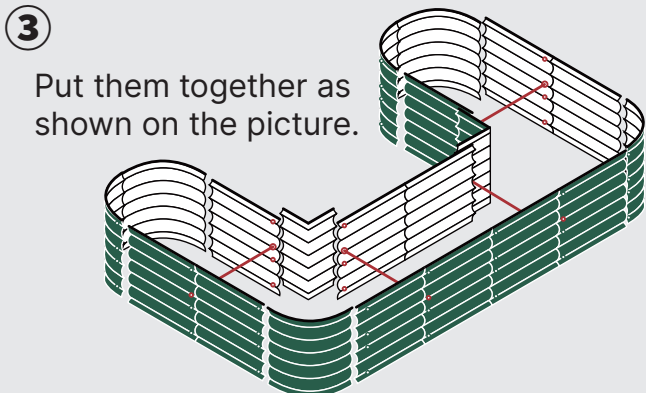
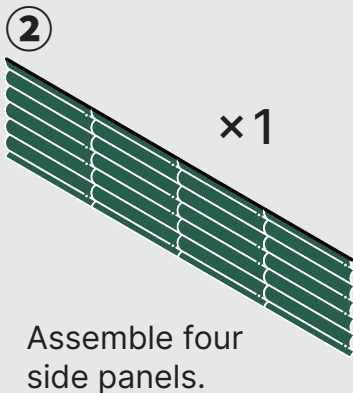
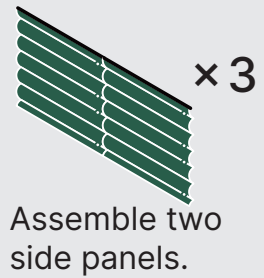
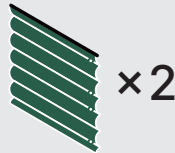
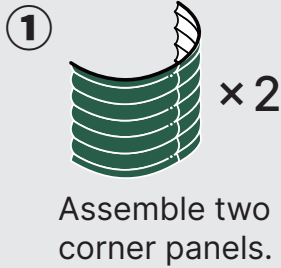
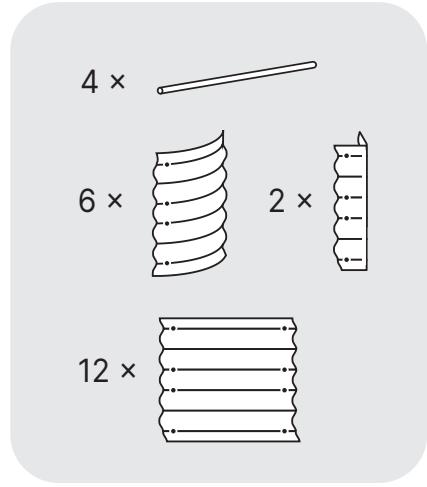
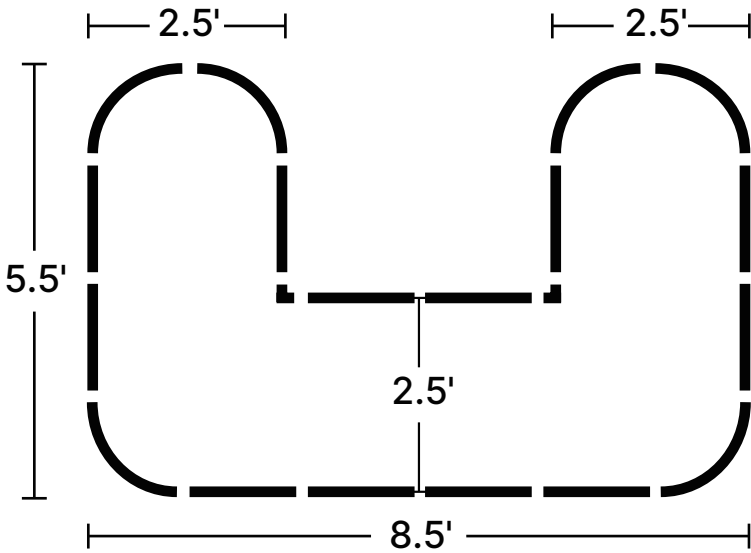



ASSEMBLY INSTRUCTION

SPECIAL SHAPES

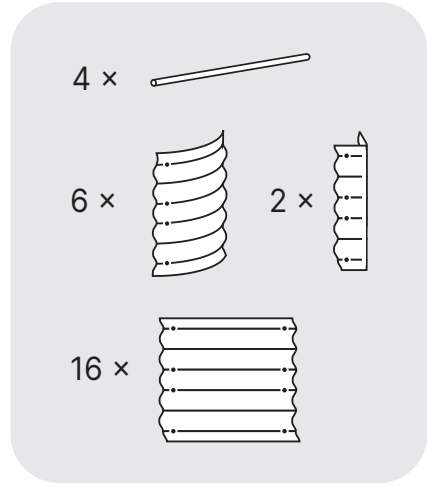
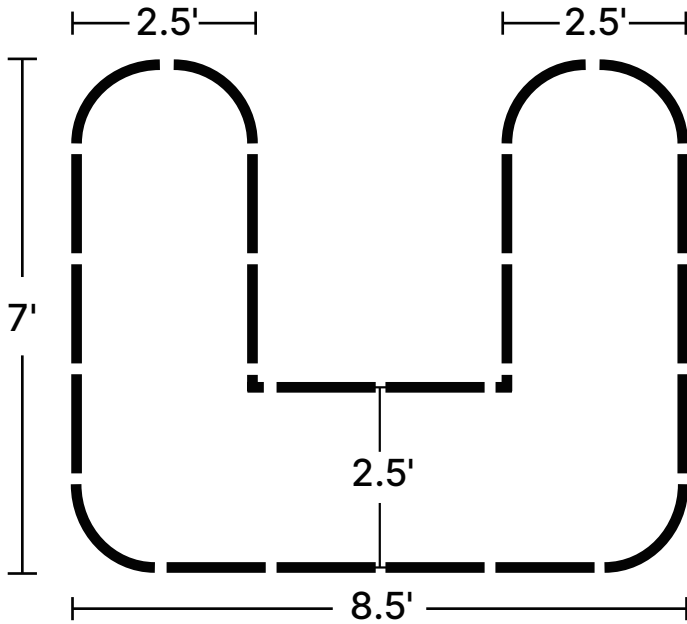
U Shaped Large

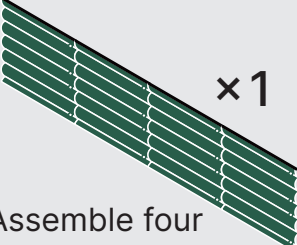

1  x 2  x 2  x 2  x 1

Assemble two corner panels. One corner panel One straight corner panel Assemble four side panels.

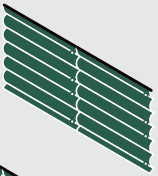
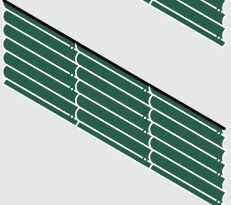
2  x 3  x 2

Assemble two side panels. Assemble three side panels.

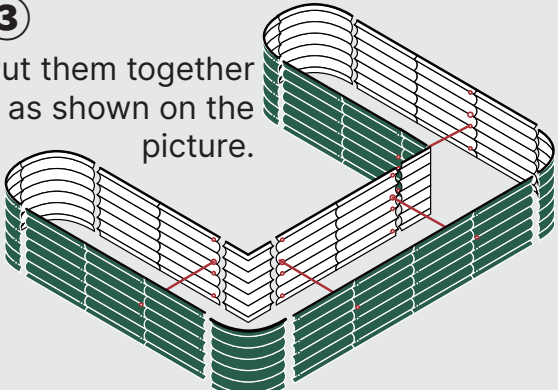
3 

Put them together as shown on the picture.

ASSEMBLY INSTRUCTION

SPECIAL SHAPES

2 Terraced

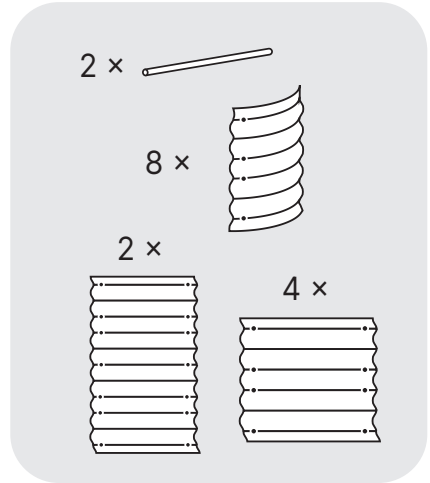
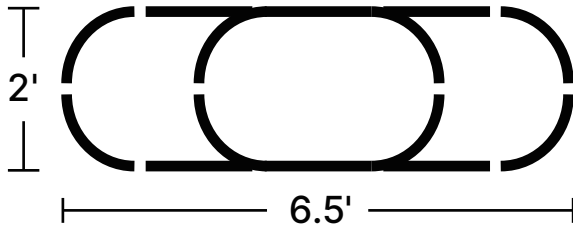

①



x 4

Assemble two 17" corner panels.

②

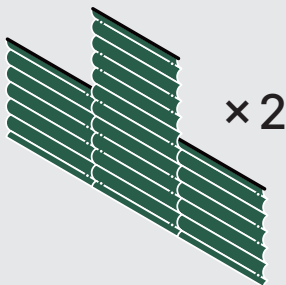

x 2

Assemble one 32" side panel and two 17" side panels.

③

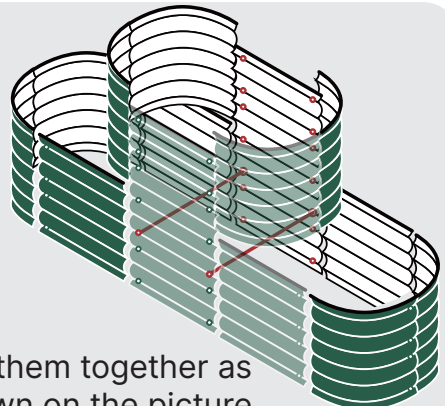

Put them together as shown on the picture.

ASSEMBLY INSTRUCTION

SPECIAL SHAPES

3 Terraced

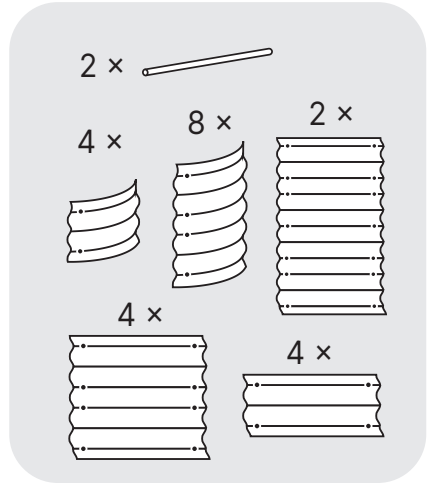
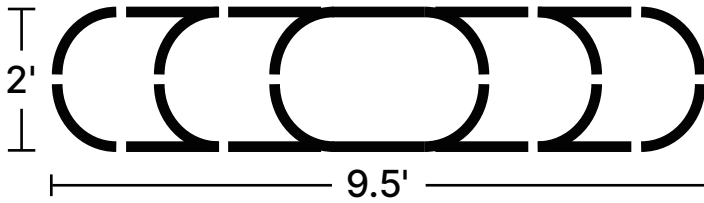

①

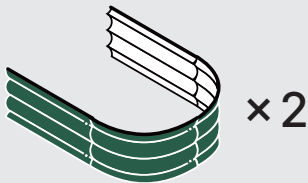

Assemble two 8" side panels and two 8" corner panels.



Assemble four 17" corner panels.

②

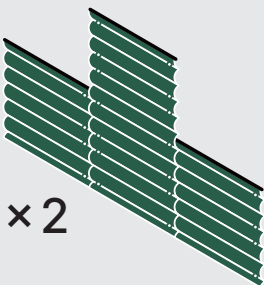

Assemble one 32" side panel and two 17" side panels.

③

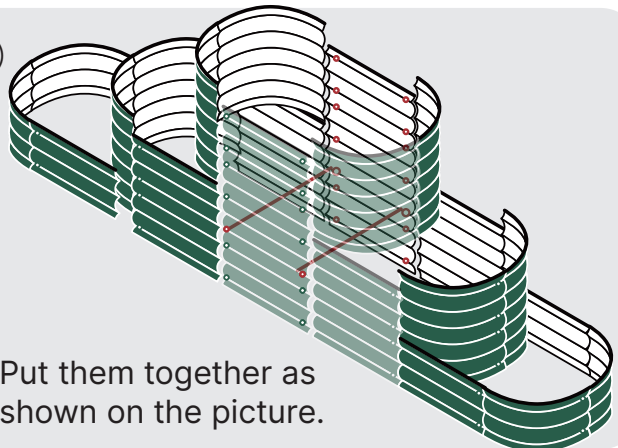

Put them together as shown on the picture.

ASSEMBLY INSTRUCTION

SPECIAL SHAPES

17" Tall Rectangle Large L Shaped

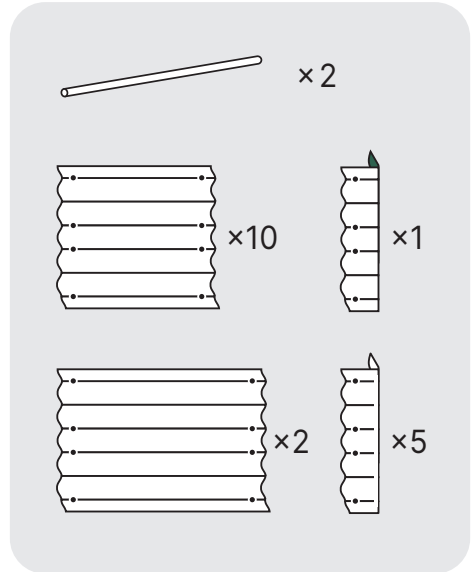
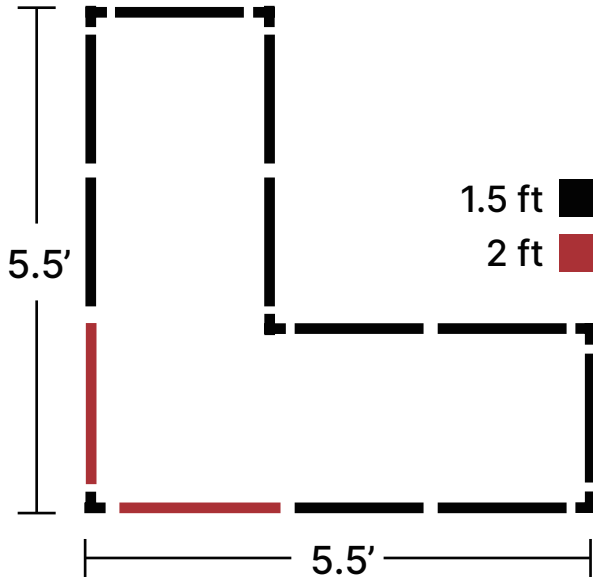

①

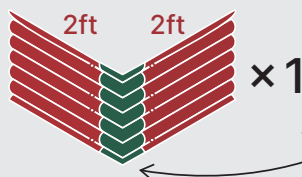

5 pieces total

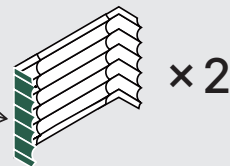

Assemble two 2ft side panels and one external corner panel.

Assemble one 1.5ft side panels and two external corner panel.

②

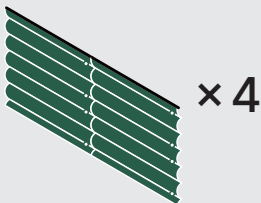

Assemble two 1.5ft side panels.

③

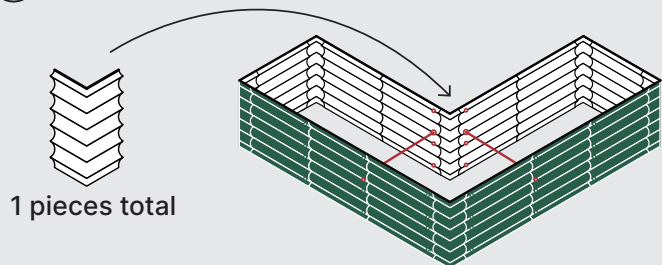

Put them together as shown on the picture.

ASSEMBLY INSTRUCTION

SPECIAL SHAPES

17" Tall Rectangle Large U Shaped

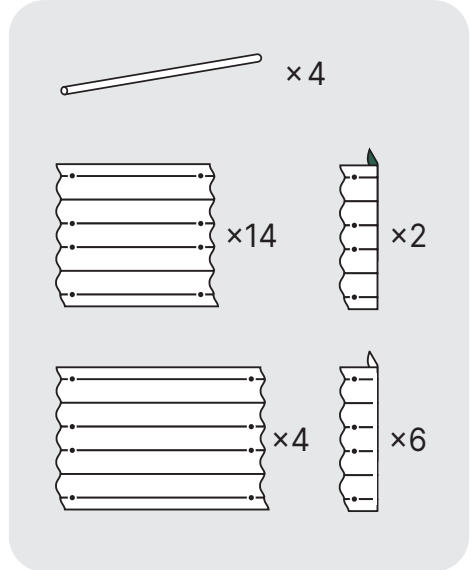
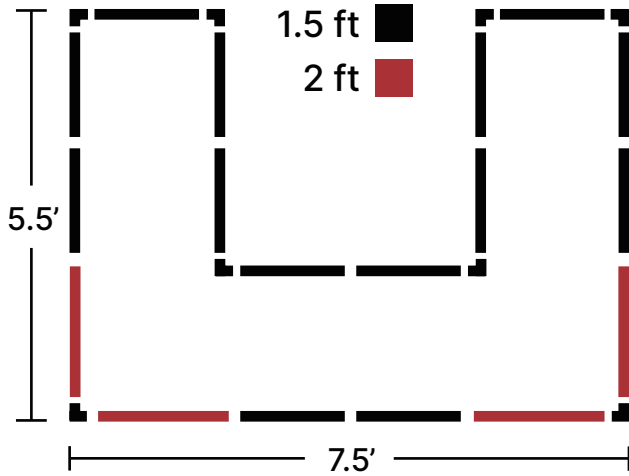

1

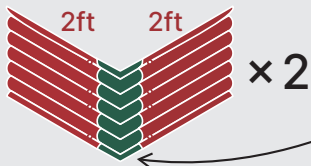

Assemble two 2ft side panels and one external corner panel.

5 pieces total

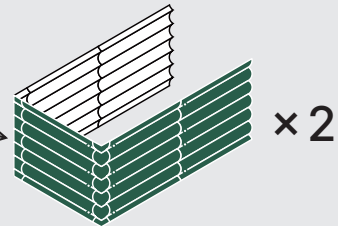

Assemble five 1.5ft side panels and two external corner panels.

2

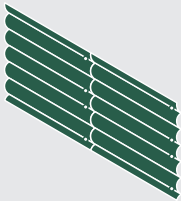

Assemble two 1.5ft side panels.

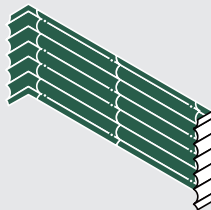

Assemble two 1.5ft side panels and two inside corner panels.

3

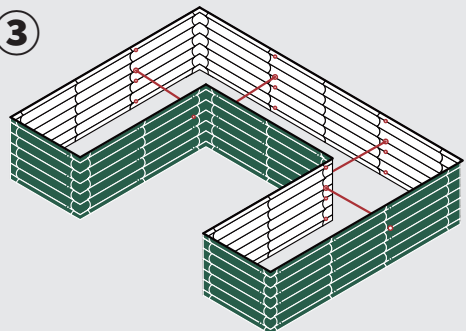

Put them together as shown on the picture.

ASSEMBLY INSTRUCTION

32" Tall 3 Tiers

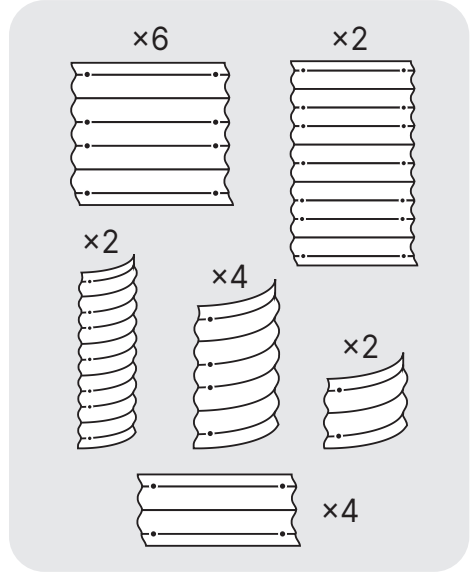
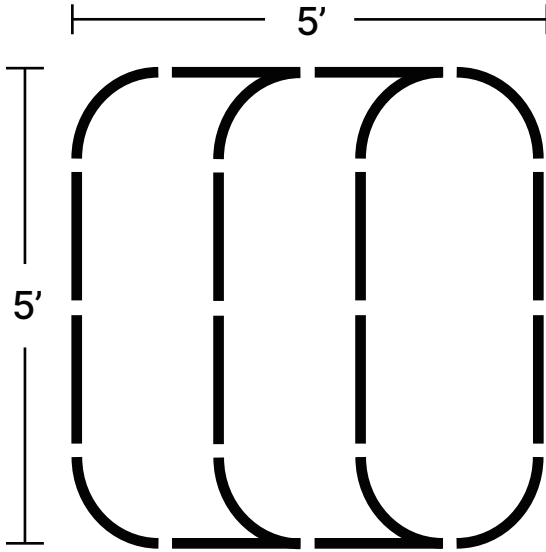

1

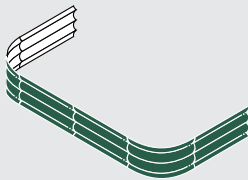

Part A: 8" tall

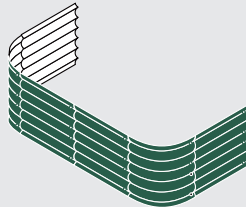

Part B: 17" tall

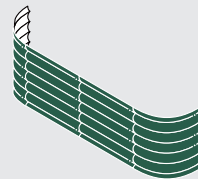

Part C: 17" tall

2

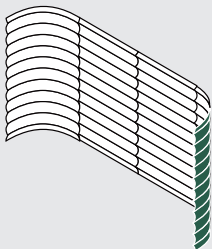

Part D: 32" tall

3

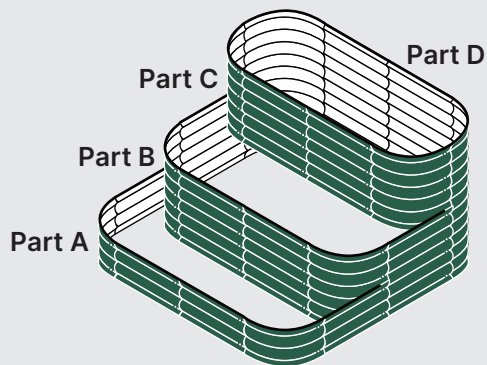

Put them together as shown on the picture.

ASSEMBLY INSTRUCTION

SPECIAL SHAPES

New Moon

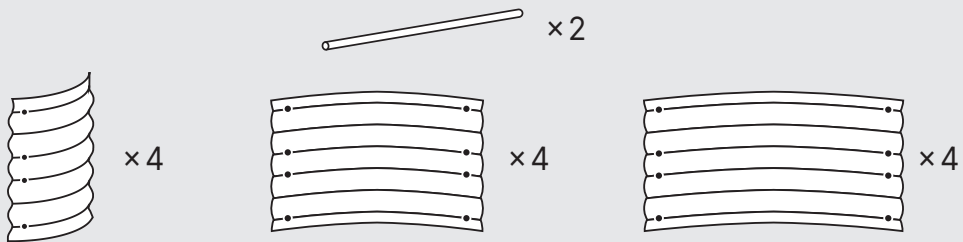
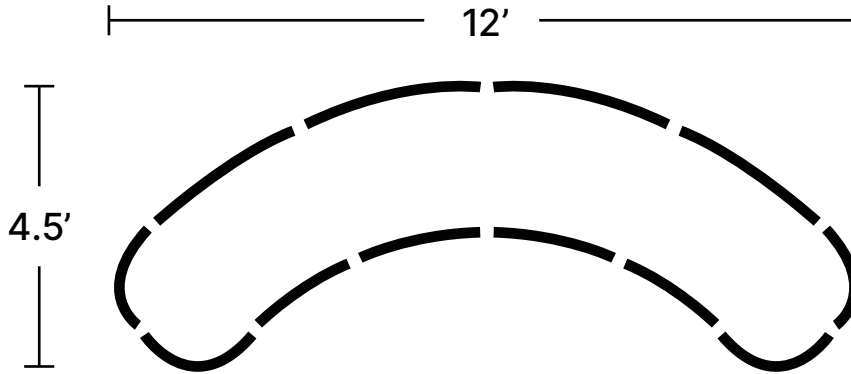

①

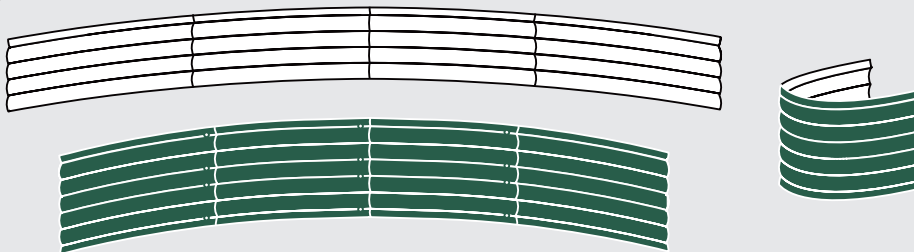

②

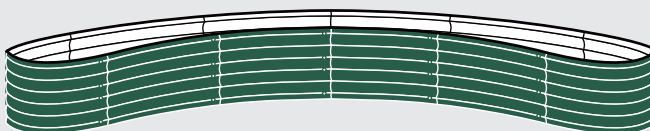

Put them together as shown on the picture.

ASSEMBLY INSTRUCTION

EXTENSION KIT

Extension Panels

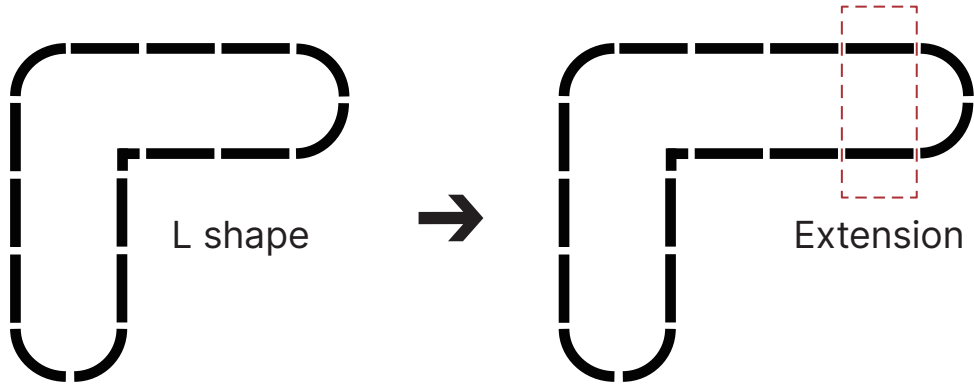

Extension Kit Package:

2 ×

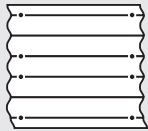

10 ×

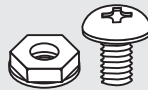

Extension Rod

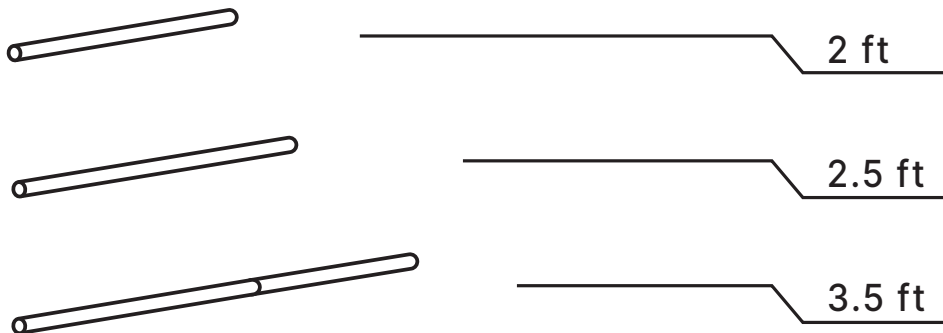

*3.5ft rod is combined by one 2ft rod and one 1.5ft rod.

*Contact us if you're not sure about how to place rods on a customized shape.

CERTIFICATION

SGS

Test Report No. SHAECC10706501 Date: 06 May 2021 Page 1 of 10

BAOSHAN IRON & STEEL CO.,LTD.(BAOSHAN BASE)
NO.151 MOHE ROAD, BAOSHAN, SHANGHAI, CHINA

The following sample(s) was/were submitted and identified on behalf of the clients as: Cold rolled steel, oiled, including full hard coil

SGS Job No.: SP21-011048 - SH
Date of Sample Received: 16 Apr 2021
Testing Period: 16 Apr 2021 - 22 Apr 2021
Test Requested: Selected test(s) as requested by client.
Test Method: Please refer to next page(s).
Test Results: Please refer to next page(s).
Conclusion: Based on the performed tests on submitted sample(s), the results of Cadmium, Lead, Mercury, Hexavalent chromium, Polychlorinated biphenyls (PCBs), Polychlorinated dibenzo-p-dioxins (PCDDs) and Phthalates such as Bis(2-ethylhexyl) phthalate (DEHP), Butyl benzyl phthalate (BBP), Dibutyl phthalate (DBP) and Dioctyl phthalate (DOP) comply with the limits as set by RoHS Directive (EU 2002/95) amending Annex II to Directive 2011/65/EU.

Signed for and on behalf of
SGS-CSTC Standards Technical Services (Shanghai) Co., Ltd.

Helen Liu
Report reviewer



Member of the SGS Group (2002-5)

Paints & Coatings
Product Safety & Regulatory Affairs
North America

AkzoNobel

**Regulatory Statement
Incidental Food Contact**

PRODUCT NAME: Mastel F4100 Narkong White
Other References: AH4A3J4*8338
Date of Statement: June 15, 2021

United States Department of Agriculture
USDA: Incidental Food Contact Materials

The above listed coating is acceptable for use as an incidental food contact coating in establishments under the Federal meat and poultry products inspection program.

This product is safe and effective under the conditions of use as prescribed in our product literature (e.g. Technical Data Sheet). The coating is permitted to be used on walls, ceilings, floors and structural steel.

This statement is void in the event of sanding, grinding or disturbing of the cured coating.

This coating is not authorized for use on any surface where there is direct or prolonged contact with food.

Canada: Canadian Food Inspection Agency
Incidental Food Contact Materials

The above listed coating is acceptable for use as an incidental food contact coating applied to construction materials used in rooms where food is manufactured, stored, packaged, received or shipped.

The coating is free of any noxious constituents and will not be a source of food contamination through its life cycle if used as prescribed in our product literature (e.g. Technical Data Sheet). The coating is permitted to be used on walls, ceilings, floors and structural steel.

This statement is void in the event of sanding, grinding or disturbing of the cured coating.

This coating is not authorized for use on any surface where there is direct or prolonged contact with food.

If AkzoNobel can be of any further assistance please do not hesitate to contact your AkzoNobel Paints & Coatings representative.



Please note that the above information is correct to the best of available knowledge at the time of writing. The coating must be applied and cured in accordance with the conditions specified in the applicable technical data sheet and/or any other instructions from AkzoNobel, and in accordance with good manufacturing practices.

CTC

Certificate of Registration
Certificate No. 446Q2011103185

Awarded to
Foshanshi Dazong Metal Products Co., Ltd.

Organization Code No. Unified Social Code 31440609MA3D2J4G
Address: The Factory in the Industrial Zone, Heidai to Shuangfeng Furniture Factory on the West Side of Ma Xian Road, Ma Village, Beijiao Town, Shunde District, Foshan City, Houshai (Declaration of Residence)

Qingdao CTC Inspection & Certification CO.,LTD (CTC) certify that the Quality Management System of the above organization has been assessed and found to be in accordance with the requirements of the standard:

GB/T19001-2016/ISO 9001:2015

SCOPE OF CERTIFICATION/REGISTRATION

Sitting, strengthening and shearing of steel and steel coils, sales and storage of steel and steel coils (excluding hazardous chemicals) (Construction-based operations requiring qualification permits)

This certificate is made valid when user with certification scopes and the requirements of applicable laws and regulations. These requirements include but are not limited to administrative permits, scope of qualifications and CCC requirements.

Subject to operation conditions in requirement conformity with Quality Management System, This Certificate is valid for a period of three years only.

Date from Nov (2020) To May (2023)

The effectiveness of this Certificate shall be validated by periodic surveillance audit of CTC for maintenance. The time limit of the certificate is to Oct 22nd, 2021, please conducting the surveillance of re-certification assessment before Oct 22nd, 2021. If the assessment is overdue, the certificate is invalid.

Signed for and on behalf of:





The certificate information is valid on: Our company Web: www.guozhuo.com, CNCA official web: on line on QINGDAO CTC INSPECTION & CERTIFICATION CO., LTD
E-MAIL: QINGDAO@QINGDAO.COM

30 years warranty for Steel Structure

Referring to the quality of zinc-aluminum-magnesium alloy coated steel in accordance with specifications including (SGS 0014-2020, YBT 4761-2019, JIS G3323-2012, AS 1397-2011, and type 1 in ASTM A1066/A1066M-2014, this warranty covers the steel structure integrity of hot-dip zinc-aluminum-magnesium alloy coated steel sheet, coated with 275 g/m², used for steel structure for a period of 30 years without red rust and a period of 35 years without perforation, from the date of shipping by Shougang Jingang United Steel Co., Ltd.

Application conditions

- (1) Situated in areas with a distance of at least 1,000 meters from the seafloor and without heavy industrial pollution (atmospheric corrosivity category C3 for steel from EN ISO 12944-2: 2017).
- (2) Temperature does not exceed 100°C.
- (3) Exposed to moderate corrosive emissions, in other words excluding the fallout of caustic chemical products, deposits or particles of heavy metals such as lead, copper or stainless steel/aluminum products such as ash, impregnated wood, wet insulation materials such as graphite, scrap, soil, animal excrement or oil.
- (4) Without mechanical or chemical damage on the coating.
- (5) Without food layer thinning due to deep stamping.
- (6) Without the effects of other uncontrollable or unforeseeable disasters or natural disasters.

All warranty claims should be sent as soon as possible in detail the precise identification of the materials deemed to be non-compliant, including the order number, the invoice number, the coil number, the shipping date and the installation date and project acceptance record.

Final interpretation right belongs to Shougang Jingang United Steel Co., Ltd. (Shougang Jingang United Steel Co., Ltd.)

Shougang Jingang United Steel Co., Ltd. (Shougang Jingang United Steel Co., Ltd.)
Date: Sep 2020





Western USA Warehouse

2646 River Ave #A Rosemead CA 91770



Eastern USA Warehouse

1101 Tonnele Ave, North Bergen, NJ 07047



German Warehouse

DE02 Kasseler Str. 7 Buseck, Hessen



UK Warehouse

UK03 Unit 1, Panattoni Park, Weedon Rd, Harpole, England



Guangzhou Branch Address

Room 401, No.17 Lv An Street, No.647 Guangzhou, Guangdong



Hong Kong Office Address

Unit 2, 22/F, Richmond Commercial Building 109 Argyle Street,
Mong Kok, Kowloon Hong Kong SAR



support@vegega.com



+1 3474620771



VEGEGA.



www.vegega.com